

Regenerative Bidirectional DC Source

RBS Series

INSTRUCTION MANUAL



ISO-9001 CERTIFIED MANUFACTURER

GW INSTEK

This manual contains proprietary information, which is protected by copyright. All rights are reserved. No part of this manual may be photocopied, reproduced or translated to another language without prior written consent of the Good Will company.

The information in this manual was correct at the time of printing. However, Good Will continues to improve products and reserves the right to change specification, equipment, and maintenance procedures at any time without notice.

Good Will Instrument Co., Ltd.

No. 7-1, Jhongsing Rd., Tucheng Dist., New Taipei City 236, Taiwan.

Table of Contents

SAFETY INSTRUCTIONS	3
GETTING STARTED	8
Product Introduction.....	9
Functions and Features.....	10
Function Introduction.....	12
Appearance.....	18
UNPACKING AND INSTALLATION	22
Unpacking and Inspection.....	23
Operating Environment.....	24
Input Wiring.....	26
Output Wiring.....	27
OPERATION	30
Preparation and inspection before use.....	33
Power on.....	34
General function.....	35
Operating Modes: Power Supply and Load.....	38
Source mode.....	39
Sequence Mode(Seq. Mode).....	49
Photovoltaic (PV) Mode.....	57
Settings Overview.....	68
Battery simulation mode.....	79
Battery charge and discharge mode.....	87
Load mode.....	93
Parallel and Series power supplies.....	99
Shutdown.....	103
INSPECTION AND MAINTENANCE	104
Maintenance and Care.....	105
Alarm code list.....	107
Storage and Transportation.....	108

TROUBLESHOOTING	109
COMMUNICATION INTERFACE	112
Communication Interface Description	113
RBS Communication Protocol	116
Modbus Communication Protocol (RTU and TCP)	141
CAN Communication Protocol	161
SCPI and command description	171
SCPI Communication Protocol	173
SCPI Communication List	175
Common Commands	179
Instrument Commands FETCH/MEASURE System	181
OUTPUT System.....	183
SOURCE System	186
BISOURCE System	188
LOAD System.....	190
LIST System*	192
SAS System (For some models only).....	198
EN System (For some models only)	200
SANDIA System (For some models only)	202
SOLAR System (For some models only)	205
BASIMULAR System.....	207
CHARGE System.....	212
SYSTEM Subsystem.....	219
Supplementary Description of the communication protocol	220
PC Control Software.....	221
APPENDIX	225
Software version	225
Specifications.....	226
RBS Dimensions	232

S SAFETY INSTRUCTIONS

This chapter contains important safety instructions that you must follow during operation and storage. Read the following before any operation to insure your safety and to keep the instrument in the best possible condition.

Safety Symbols

These safety symbols may appear in this manual or on the Product name.



WARNING

Risks! Fail to follow the instruction will cause personal injury. Do not operate the instrument before understanding the instruction.



CAUTION

Risks! Fail to follow the instruction may cause death or injury. This mark prompts for procedures, practices and conditions etc.



Electricity shock!



Note

Precautions: Refer to the instructions in the user manual to avoid damage to the device or personnel injury.



High Temp.: The temperature is higher than the limit for human body. Do not touch to avoid injury.



Protective Conductor Terminal



Earth (ground) Terminal



AC: Alternating Current



DC: Direct Current





AC/DC: AC or DC



Do not dispose electronic equipment as unsorted municipal waste. Please use a separate collection facility or contact the supplier from which this instrument was purchased.

Safety Guidelines

Pay attention to the precautions in this manual during operation or maintenance. We will not be responsible for any personnel injury or damage to the machine due to failing to observing these precautions.

- General Guideline • Read this manual carefully before using this equipment and keep it well.
-  WARNING • Do not use this product for purpose other than those described in this manual.
-  CAUTION • Check the power ratings before power ON. Make sure the switch is at OFF position.
- Earth: Ground the device firmly before power on.
 - Precautions (earth): Never disconnect the internal/external earth wires or earth terminals to avoid personnel injury due to shock.
 - Fuse: Only use fuse with required rated current/voltage or special one (normal fuse, time delay etc). Never use fuse of other size or short-connect the fuse to avoid shock or fire.
 - Do not remove the housing.
 - The operator shall not dismantle the case. Only qualified engineers can change or adjust the parts.
 - Never operate the device in explosive or corrosive environment.
 - Never operate the device in flammable gas or corrosive environment.
 - Turn off the power before handling the unit, and disconnect all wires.
 - This unit weights 20 Kg or more, which can be found in the manual. Handle the unit by two persons or more.

-
- Be careful during handling this unit to avoid falling.
 - Deliver this product accompanied with this manual.
 - Check if the AC power supply is consistent with the size of the fuse. Check the power line. Disconnect the power line or turn off the power switch before inspection.
 - Stop operation immediately in case of any abnormalities or faults. Disconnect the power line or turn off the power switch in the distribution box. Do not use it before it is repaired.
 - Use cables with high over current capability for output or load lines.
 - Keep water or metal objects out of this product.
-

Cleaning

- Disconnect the power cord before cleaning.
 - Use a soft cloth dampened in a solution of mild detergent and water. Do not spray any liquid.
 - Do not use chemicals containing harsh materials such as benzene, toluene, xylene and acetone.
-

Operation Environment

- Location: Indoor, no direct sunlight, dust free, almost non-conductive pollution (Note below)
- Relative Humidity: 20 % to 90 % RH
- Altitude: < 1000 m
- Temperature: 0 °C to 40 °C

**Note**

(Pollution Degree) EN 61010-1 specifies the pollution degrees and their requirements as follow. The device falls under degree 2.

Pollution refers to “addition of foreign matter, solid, liquid, or gaseous (ionized gases), that may produce a reduction of dielectric strength or surface resistivity”.

- Pollution degree 1: No pollution or only dry, non-conductive pollution occurs. The pollution has no influence.
- Pollution degree 2: Normally only non-conductive pollution occurs. Occasionally, however, a temporary conductivity caused by condensation must be expected.
- Pollution degree 3: Conductive pollution occurs, or dry, non-conductive pollution occurs which becomes conductive due to condensation which is expected. In such conditions, equipment is normally protected against exposure to direct sunlight, precipitation, and full wind pressure, but neither temperature nor humidity is controlled.

Storage environment

- Location: Indoor
- Temperature: -10 °C to 70 °C
- Humidity: 20 % to 80 % RH

Disposal

Do not dispose this instrument as unsorted municipal waste. Please use a separate collection facility or contact the supplier from which this instrument was purchased. Please make sure discarded electrical waste is properly recycled to reduce environmental impact.

GETTING STARTED

Guide	<ul style="list-style-type: none">• Product introduction• Product functional characteristics• Panel description
Product Introduction	9
Functions and Features	10
Function Introduction.....	12
Product Function	12
Front panel function	16
Interface	16
Accessories	16
Appearance	18
Front Panel.....	18
Rear Panel	21

Product Introduction

The principle of RBS series Regenerative Bidirectional DC Source (hereinafter referred to as RBS power) is shown in Figure 1-1-1.

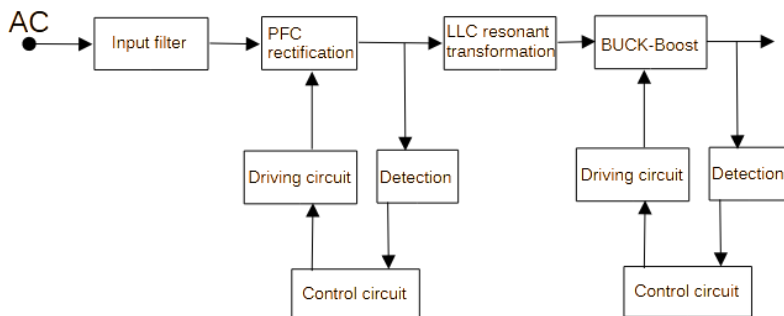

Figure 1-1-1 Block Diagram

Functions and Features

RBS series Regenerative Bidirectional DC Source has the following technical features:

- Power grid feedback function: It has both power and load characteristics, and in addition to DC power performance, it achieves automatic energy feedback to the load function of the power grid, with outstanding advantages of energy conservation, consumption reduction, and green environmental protection.
- With wide range output capability, offering up to 3 times the output range compared with fixed-range power supplies of the same power class.
- Using active power factor correction technology, full load power factor more than 0.99.
- Using high frequency LLC multi-resonance inverter, the efficiency of the whole machine is up to 0.93.
- Supports three operating modes – constant voltage (CV), constant current (CC), and constant power (CP) – to accommodate a wide range of testing requirements.
- Powerful programmable function, flexible function setting.
- Solar cell array simulation with I-V characteristics, based on a built-in mathematical I-V curve model.
- Built-in EN50530, Sandia and other standards of photovoltaic test function.
- Equipped with battery simulation function, built-in nearly 10 commonly used battery curves, and customizable battery curves.

- Equipped with battery charging and discharging function.
- Load mode, including CR constant resistance mode.
- Integrated high-precision voltage and current measurement with superior output stability.
- Lead voltage drop compensation terminal, can achieve high current work output lead voltage drop compensation.
- Complete protection function to ensure the normal operation of power equipment and load safety.
- High-brightness color LCD with a refined design, offering simple and intuitive operation.
- Output can be configured in parallel for all units; series configuration is exclusively supported on 100V output models.

Function Introduction

Product Function

- Constant power wide range output capability

The RBS power supply adopts a wide range output design, which extends the voltage-current output curve to provide users with a wider combination of voltage and current. This makes it more flexible than traditional fixed range (rectangular) output power supplies.

A single wide range DC power supply can cover an output range several times larger than that of an ordinary fixed range power supply.

For example, a 15 kW model with 100 V / 510 A capability can output either 100 V / 150 A or 29.4 V / 510 A within the same 15 kW power envelope. In contrast, a traditional fixed range power supply rated at 100 V / 150 A / 15 kW can only deliver 29.4 V / 150 A (about 4.4 kW) at lower voltages.

Fig. 1-3-1 and Fig. 1-3-2 illustrate this comparison.

Figure 1-3-1

Operation range of conventional “Fixed Range” power supplies

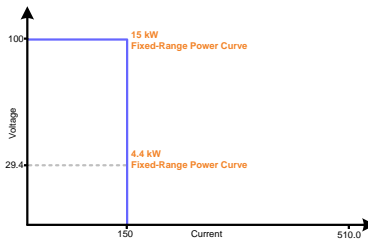
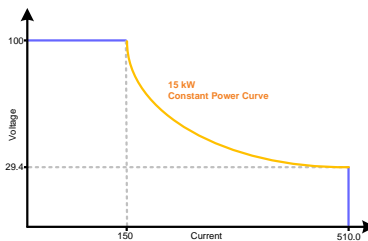

Figure 1-3-2

Operation range of RBS series power supplies



Comparison of Output Characteristics Between RBS Wide Range Power Supply and Traditional Fixed Range Power Supply

- Constant voltage (CV), constant current (CC) or constant power (CP)

The RBS power supply supports three output operation modes: Constant Voltage (CV), Constant Current (CC), and Constant Power (CP).

- The actual operating mode depends on the settings of voltage, current, and power, as well as the resistance of the connected load.

- As illustrated in Figure 1-3-3:

- When the load resistance is R_1 and the operating point intersects the voltage setting line (V-set), the power supply operates in CV mode.

- When the load resistance is R_2 and intersects the power setting curve (P-set), it operates in CP mode.

This flexible output behavior is enabled by the wide range output design of the RBS series, which dynamically adjusts the voltage and current within the rated power envelope.

Figure 1-3-3

Constant voltage (CV)/Constant power (CP)/constant-current (CC) output characteristics

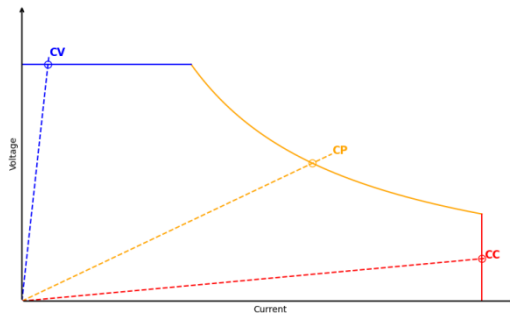

- 10 Non-Volatile Shortcut Groups for Save and Recall

To accommodate various test requirements, the power supply supports 10 shortcut groups for saving and recalling working modes. These configurations are stored in non-volatile memory, ensuring that the data is retained even after a power outage.

Users can easily store and retrieve preferred settings to improve test efficiency.

- Sequence Test Function

The Sequence test function supports up to 50 sequences, each stored in non-volatile memory.

Each sequence can contain up to 20 steps, and users can freely define the output mode – constant voltage (CV), constant current (CC), or constant power (CP) – for each step based on actual test requirements.

This allows the power supply to automatically execute complex test procedures in a time-sequenced manner to meet specific application needs.

- Photovoltaic function

The photovoltaic (PV) simulation feature supports standardized test profiles, including SAS, EN50530, and Sandia.

By entering the parameters of a PV IV curve or selecting from standard test models (e.g., EN50530 or Sandia), the power supply can simulate the output characteristics of photovoltaic panels.

This enables accurate testing of PV inverters and related devices under various irradiance and temperature conditions.

- Battery simulation function

The battery simulation feature includes built-in voltage-state-of-charge (V-SOC) curve profiles for nearly 10 common battery types.

Users can also define custom battery parameters to simulate specific battery behaviors.

During operation, the system allows for real-time visual observation of the V-SOC curve, providing intuitive insight into battery dynamics under different load or charge/discharge conditions.

- Battery charging and discharging function

The power supply supports both battery charging and discharging operations, with a variety of cutoff conditions available to ensure safe and accurate testing.

Users can configure limits based on voltage, current, capacity, time, or energy to automatically stop the charge or discharge process when preset thresholds are reached.

- Built-in short-circuit and overheat protection

The power supply is equipped with built-in hardware protection against short circuits and overheating.

When such conditions are detected, the output is immediately shut down to prevent damage and ensure the safety of the DC power system.

- Voltage, current and power Settings

The power supply allows flexible parameter adjustment through multiple input methods:

- Rotary knob for fine tuning
- Function key + numeric keypad for precise digital input
- Touchscreen interface for quick and intuitive operation

These options provide users with efficient and user-friendly control over voltage, current, and power settings.

- Power-on self-check function

Each time the system is powered on, it performs an automatic self-check to verify the integrity of internal circuits.

If any abnormal condition is detected, the system will not enter the normal operation interface, ensuring safe and reliable startup.

- Alarm Settings

The system supports comprehensive alarm and protection functions, including configurable limits for voltage, current, and other output parameters.

Users can define alarm behaviors such as prompt, ignore, or stop output, providing enhanced flexibility and safety during testing.

- Supports Up to 10 Units in Parallel Operation

Up to 10 power supplies of the same model can be connected in parallel to expand output capacity.

The rear panel includes two dedicated ports labeled PARA OUT and PARA IN, which enable Master/Slave configuration for synchronized control and load sharing among units.

Front panel function

The front panel supports both keypad and touch control for convenient operation. Users can set output voltage, current, and power, and monitor system status through the color LCD display. The main functions include:

- Output On/Off Control
- Set output voltage, current, and power values
- Save or recall shortcut memory groups
- Edit, store, and execute test sequences
- Configure system settings (alarms, protection limits, system parameters, operation modes, etc.)
- Set PV IV curves (do not support for 100V models)
- Use the battery simulation function

Interface

-Optional interfaces:RS-232, RS-485, CAN Bus, LAN and GPIB

-Communication protocols support:

SCPI/ Modbus RTU/ Mosbus TCP/ RBS (manufacturer customized protocol)

Accessories

Standard Accessories	Part number	Description	Qty.
		AC Input Connector	1
		Output terminal cover	1
		Power Cord (Length 1.5 m, voltage 750V, 4mm ² (L1, L2, L3)+ 2.5 mm ² (GND))	1
		Factory Test Report	1

		M4x10 Screw	4
		3U Handle	2
		Packing List	1
		RS232 adapter cable	1
Factory Installed Options	Part number	Description	
Two selectable options Interface	RBS-IF01	USB,RS232,RS485,CAN,LAN interface	1
	RBS-IF02	GPIB interface	1
Optional Accessories	Part number	Description	
	GTL-133	Load cable, 1.5 m, 100 A	1
	GTL-218	Load cable, 1.5 m, 200 A	1
	GTL-219	Load cable, 3 m, 200 A	1
	GTL-220	Load cable, 1.5 m, 300 A	1
	GTL-221	Load cable, 3 m, 300 A	1
	GTL-222	Load cable, 1.5 m, 400 A	1
	GTL-223	Load cable, 3 m, 400 A	1

		Packing List	1
		RS232 adapter cable	1
Factory Installed Options	Part number	Description	
Two selectable options Interface	RBS-IF01	USB,RS232,RS485,CAN,LAN interface	1
	RBS-IF02	GPIB interface	1
Optional Accessories	Part number	Description	
	GTL-133	Load cable, 1.5 m, 100 A	1
	GTL-218	Load cable, 1.5 m, 200 A	1
	GTL-219	Load cable, 3 m, 200 A	1
	GTL-220	Load cable, 1.5 m, 300 A	1
	GTL-221	Load cable, 3 m, 300 A	1
	GTL-222	Load cable, 1.5 m, 400 A	1
	GTL-223	Load cable, 3 m, 400 A	1

Appearance

Front Panel

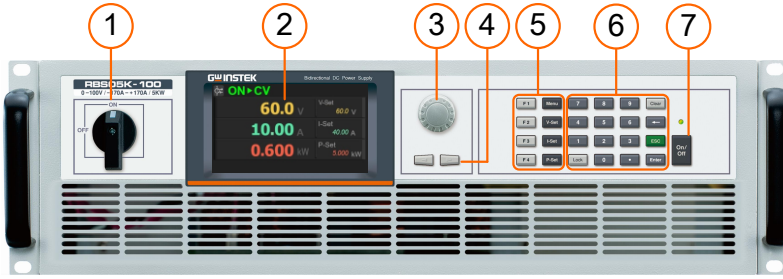

1. Power Switch



Turns the system power on or off.



Warning

Turning off the power switch does not disconnect the external input voltage.

High voltage may still be present inside the chassis. Do not open the chassis by yourself.

When servicing is required, qualified service personnel must disconnect the input power cable before opening the unit.

2. 4.3-inch TFT LCD Display Area



Equipped with a 4.3-inch color TFT LCD touch screen, this display shows set values, real-time output information, and system status.

When touch control is enabled, settings can be adjusted directly via the screen.

3. Knob



Used to adjust setting parameters such as voltage, current, and power.

By pressing the center of the knob, users can switch between different adjustment speeds for fine or coarse

tuning.

4. Direction key



Used to select modifiable items on the display.

These keys can also serve as an alternative to the touch screen, allowing users to navigate and select options on the panel when touch input is disabled or not preferred.

5. Function button area



F1-F4 key The functions of these four keys vary depending on the current interface. They provide quick access to commonly used operations and enhance user convenience.

MENU key Press to return directly to the main menu interface.

V-set key Voltage setting key. Press to adjust the output voltage using either the rotary knob or numeric keypad.

I-set key Current setting key. Press to adjust the output current using either the rotary knob or numeric keypad.

P-set key Power setting key. Press to adjust the output power using either the rotary knob or numeric keypad.

6. Digital button area
- 
- This area includes numeric keys (0–9) and function keys used for parameter input and operation control.
- | | |
|-------------------|---|
| 0~9 Number key | Used for direct numeric input of voltage, current, power, and other parameters. |
| ESC key | Cancel the current operation. |
| ← (Backspace) Key | Used to delete the last digit during numeric input. |
| Clear key | Clears all digits entered during numeric input. |
| Lock key | Locks the keypad to prevent unintended operations. |
| Enter key | Confirms the current operation or input. |

7. On/Off key and indicator
- 
- This key is used to start or stop the power output.
- The built-in indicator light shows the current output status:
- ON: Output is active
 - OFF: Output is disabled

Rear Panel

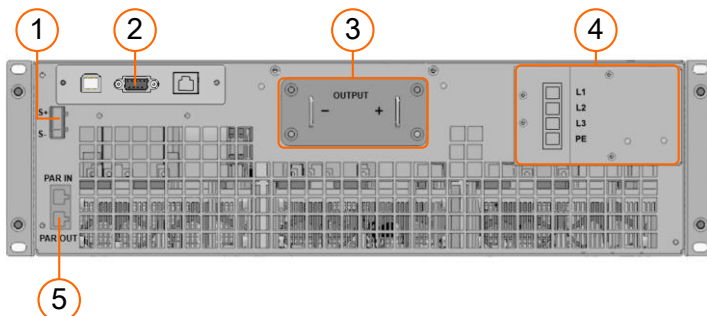

- | | |
|----------------------------|--|
| 1. SENSE interface | Used for remote voltage sensing to compensate for voltage drop across load leads. |
| 2. Communication interface | Communication interfaces USB, RS232, RS485, LAN, and CAN are integrated on a single interface card, while GPIB is provided on a separate, dedicated interface card.

(Factory Installed Options) See Figure 1-5-3 to Figure I-5-4. |
| 3. Output terminal | Consist of positive (+) and negative (-) terminals for DC output connection. |
| 4. AC Input Terminal | Used to connect to the AC mains. |
| 5. Parallel interface | Used for parallel connection of multiple units:

- PAR IN: Slave input
- PAR OUT: Master output |

Figure 1-5-3
USB, RS232,
RS485, CAN, LAN
interface

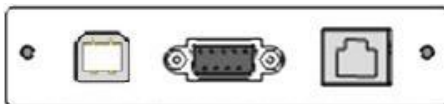
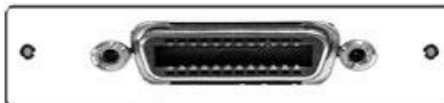

Figure 1-5-4
GPIB interface



UNPACKING AND INSTALLATION

Guide	<ul style="list-style-type: none">• Unpacking Inspection• Operating Environment• Input Line• Output Line• Section of Cable
Unpacking and Inspection	23
Inspection Before Unpacking	23
Unpacking	23
Operating Environment.....	24
Input Wiring.....	26
Output Wiring.....	27
Wiring instructions	27
Wire diameter requirement	28

Unpacking and Inspection

Inspection Before Unpacking

Carefully check the package for any signs of damage.

If damage is found, immediately notify the shipping agent to inspect the goods and record the damage for your reference.

Only proceed with unpacking if no damage is observed.

Unpacking

- | | |
|-----------|---|
| Procedure | <ol style="list-style-type: none">1. Unpack the unit according to the package requirements and remove the device.2. Verify the nameplate information to ensure the model matches your order and that all items correspond with the packing list. If discrepancies are found, contact the service center or your local agent.3. Perform a visual inspection.4. Check for scratches, dents, or metal marks.5. Ensure all connections and fasteners are secure.6. Look for any abnormalities. If damage or abnormalities are detected, contact the service center or agent immediately. The service center will arrange repair or replacement as necessary. Do not return the unit without prior notification.7. Safety Warning: Never open the cover of the unit to avoid the risk of electric shock. For any questions or concerns, contact the service center or agent. |
|-----------|---|

Operating Environment

1. Ensure adequate ventilation and heat dissipation during installation. Maintain a minimum clearance of 30 cm between the air inlet/outlet and any wall or obstruction. The unit must be kept away from corrosive substances at all times.
2. Verify that the AC input power conforms to the specified requirements before connection.
3. Operating ambient temperature and humidity conditions shall comply with the specifications of the corresponding model.
4. After installation and verification, it is recommended to power on the unit to maintain optimal operating conditions and prevent moisture ingress into critical components. For units left unused for extended periods, conduct a visual inspection prior to use. If any internal moisture is detected, ensure adequate drying before operation.

General environmental conditions:

Guide

- Installation location: Indoor use only
- Hazardous media: Keep away from flammable, explosive, or corrosive substances (e.g., alcohol, thinner, sulfuric acid, etc.).
- Heat and sunlight: Do not install near heat sources or direct sunlight.
Operating temperature: 0 °C to +40 °C
Storage temperature: -10 °C to +70 °C
- Moisture sources: Avoid installation near boilers, humidifiers, or water sources.

- Electromagnetic interference: Keep away from strong EMI/RFI sources.
 - Mechanical stress: Avoid strong vibration or mechanical shock.
 - Ventilation: Ensure proper airflow and keep a clearance of at least 30 cm around air vents. The environment should be free of dust accumulation.
 - Condensation: Avoid rapid temperature changes to prevent internal condensation. If condensation occurs, discontinue use until the unit is completely dry.
 - Weather protection: The unit must be protected from rain and outdoor exposure.
-



Ingress of liquids or solid objects through the top vents may cause catastrophic failure of the power unit, including the risk of explosion.

Input Wiring

For three-phase input, the wiring terminals on the rear panel of the chassis are shown in Figure 2-1. Before connecting cables, ensure that the input power supply is cut off. Cable connections are marked with L1, L2, L3, and \oplus grounding labels respectively

Power supply voltage range: line voltage 342 VAC to 510 VAC.

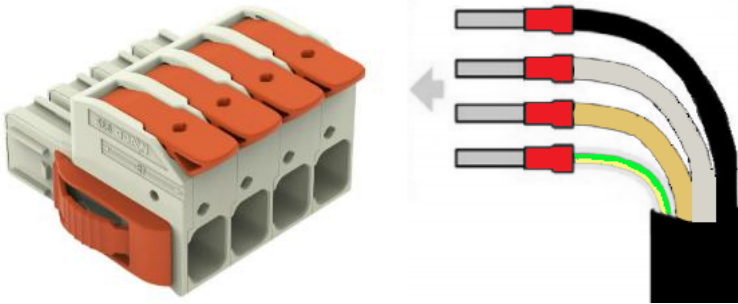

Figure 2-1 Input terminals on the rear panel

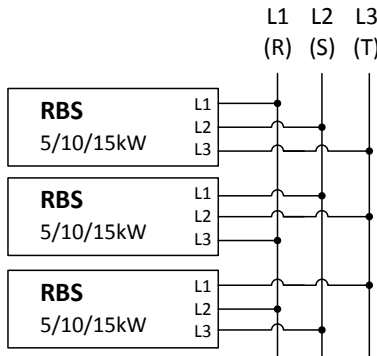

Figure 2-2 Staggered connection of the input line



Warning

Before connecting cables, ensure that the input power is disconnected. Leakage current may cause the chassis to be energized. The PE at the grounding terminal must be well grounded to protect personnel.

Output Wiring

Wiring instructions

- Method 1** Connection method when the lead pressure drop compensation function is not used
- Connect the output terminal to the load as shown in Figure 2-3 (a). Use a short route to connect the positive output terminal to S+ and the negative output terminal to S-. In this case, the lead voltage drop is not compensated, and the voltage displayed is the output voltage of the power supply, not the voltage at both ends of the load.
- Method 2** Connection method when using the lead pressure drop compensation function
- Connect the output terminal to the load as shown in Figure 2-3 (b). The positive output terminal and S+ are connected to one end of the load at the same time, and the negative output terminal and S- are connected to the other end of the load at the same time. The voltage displayed is the actual voltage at both ends of the load to realize the function of lead voltage drop compensation.



Not use the lead voltage drop
Compensation function(a)

Use the lead voltage drop
Compensation function(b)

Figure 2-3 Output cable connections



If the output terminal of the power supply is not connected to the load and only the SENSE cable is connected, the current flows out of the SENSE cable, which will damage the internal components of the power supply.



If the switch is in a closed state and the external output terminal carries high voltage, users should not touch the output terminal to prevent electric shock. When customer service personnel carry out maintenance, they should first stop the power output and remove the input cable.

Wire diameter requirement

Output Power	Input wire diameter
5 kW	BVR 2.5 mm ²
10 kW	BVR 4 mm ²
15 kW	BVR 4 mm ²
18 kW	BVR 4 mm ²
21 kW	BVR 6 mm ²
30 kW	BVR 10mm ²

Output Current	Output wire diameter
Below 48 A	BVR 6 mm ²
48 A to 65 A	BVR 10 mm ²
65 A to 91 A	BVR 16 mm ²
91 A to 120 A	BVR 25 mm ²
120 A to 148 A	BVR 35 mm ²
148 A to 187 A	BVR 50 mm ²
187 A to 231 A	BVR 70 mm ²
231 A to 283 A	BVR 95 mm ²
283 A to 326 A	BVR 120 mm ²
326 A to 374 A	BVR 150 mm ²
Note 1: output voltage exceeds 750 V	High voltage harness 10 mm ²
Note 2: Parallel cables above 374 A can be used. For example, BVR120x2 mm ² can be used for 510 A models (the current is expanded to allow for allowance for uneven flow problems)	

Table 2-1 Wire diameters



Do not use undersized cables, as this may result in overheating or potential safety hazards.



When the voltage exceeds 750 V, use a high-voltage cable of the corresponding level to avoid risks.

Output shield

After the power output cable is connected, install the output shield , protect output terminals and prevent false electric shock.

As shown, the guard will be attached to the output terminal position on the rear panel of the power supply using 2 screws.

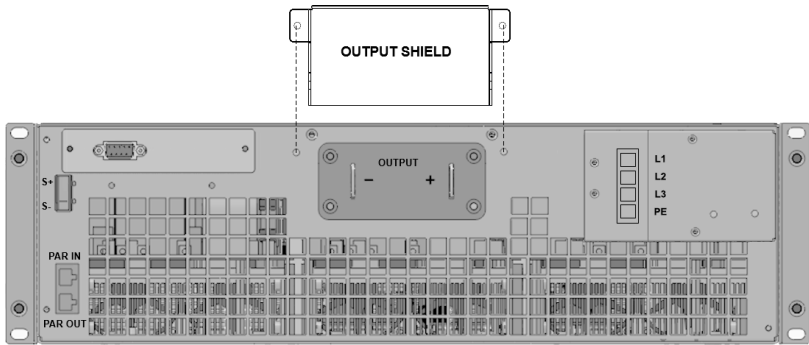

Figure 2-4 Output shield installation



Output of DC Voltage, Please be Caution.

Please make sure the output terminal is not charged before any touch of it.

1. Please stop the output of Power supply before turning off the power input.
2. After unexpected power off, please wait 2 minutes and confirm the output terminal has no electricity charge before further operation.
3. Even after the RBS is powered off, voltage may still remain at the output terminals. Please wait 2 minutes and confirm the output terminal has no electricity charge before further operation.

OPERATION

Guide	<ul style="list-style-type: none"> • Preparation and inspection before use • Power on and off operations • Normal working mode operation • List test mode operation • Photovoltaic mode (some high voltage models) operation • Power Settings • Battery Simulation mode operation • Battery Charge & Discharge mode operation • Parallel and Series power supplies
Preparation and inspection before use	33
Power on	34
General function	35
Menu and Menu Function Keys	35
Lock function and Lock function key	36
Operating Modes: Power Supply and Load	38
Power Supply and Sequence Functions	38
Mode Switching Behavior	38
Dedicated Load Mode	38
Source mode	39
Source mode interface description	39
Status Display Area	40
Parameter Setting Area	40
Control Operation Area	41
Setting Source Working Mode Parameters	41
Touch Input for Value Modification	41
Selecting Parameters via Function Keys	42
Modifying Parameters via Keypad / Knob	43
Source Mode Operations	43

Source Mode – Output On State	44
Source Mode – Preset Function	45
Bidirectional Parameter Mode	46
Sequence Mode(Seq. Mode)	49
Sequence Test — Standby Status.....	49
Sequence Test — Sequence Test Browser	50
Sequence Test — Sequence Edit	51
Sequence Test — Step Edit	52
Sequence Test — Run Mode	54
Sequence Test — Pause	54
Sequence Test — Single Step Operation	55
Sequence Test — Example Configurations	55
Photovoltaic (PV) Mode	57
PV Standby State.....	57
Stability Notice.....	57
PV IV Mode Description	57
PV SAS Standby Mode.....	59
PV EN50530 Standby Mode	60
PV Sandia Standby Mode	61
PV SAS2 Standby mode	62
PV Setting.....	63
PV mode - Running	65
PV mode - online adjustment.....	66
Settings Overview.....	68
List of Setting Parameters	68
Time Setting.....	75
Viewing the Black Box.....	76
Network Port Settings (Optional)	77
Battery simulation mode.....	79
Users can also customize battery parameters for simulation.	79
Battery Simulation Standby and Parameter Interface	79
Battery Simulation Parameters.....	82
Battery Simulation - Running	84
Battery charge and discharge mode	87
Battery Charge and Discharge Setting Screen	88
Description of battery charging and discharging parameters	89
Battery Charging and Discharging - Running	90
Load mode	93
Load mode introduction	93
Load Mode – Standby State	95

Load Mode - Operating State.....	96
Additional Notes on Load Mode.....	96
Parallel and Series power supplies	99
Parallel Connection.....	99
Series Connection.....	102
Shutdown	103

Preparation and inspection before use

- Guide
1. Ensure that the input and output lines of the power supply are correctly connected.
 2. Please read the safety and warning signs posted on the instrument before use.

Power on

Turn on the power switch. The welcome screen is displayed after a few seconds.

In the welcome screen, after about 5 seconds to enter the power operation interface (the corresponding working mode screen under power shutdown), otherwise it will enter the corresponding alarm state according to the self-detected error.



Note

There is a significant difference between the temperature at which the power supply reaches internal thermal equilibrium and the storage room temperature. Immediately after startup, if the unit is used without warm-up, the output accuracy—such as voltage, current, and power—may deviate slightly from the specified accuracy.

To ensure accurate performance, allow the power supply to warm up for several minutes or longer, depending on the ambient temperature and load conditions.

General function

Menu and Menu Function Keys

The menu interface is shown in Figure 3-3-1 and Figure 3-3-2. The difference between the two is that models with 500 V output and above include an additional Photovoltaic (PV) operating mode.

In the menu screen, users can access various operating modes by:

- Pressing Function Keys (F1-F4)

- Pressing Numeric Keys (1-3)
- Or directly tapping the corresponding icons on the touchscreen (when touch function is enabled)

Figure 3-3-1

Main Menu
(without PV
Mode)

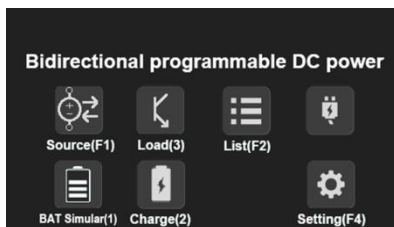
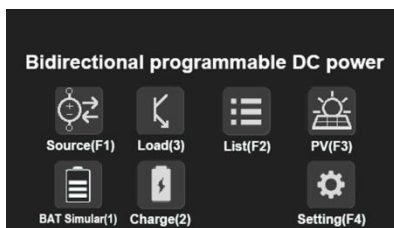

Figure 3-3-2

Main Menu (with
Photovoltaic
Mode)



The MENU key can be pressed at any time during standby to return directly to the main menu.



Note

Directly clicking the Menu key in the editing state will not save the modified data.

Lock function and Lock function key

The power supply is equipped with a lock function.

When the unit is left unattended for an extended period, pressing the Lock key will disable the keypad and touch screen to prevent accidental operation.

Figure 3-3-3
Locked Status



The locked status is shown in Figure 3-3-3. There is a lock icon in the upper right corner. The operable area will turn into gray font, indicating that no operation can be performed. In the locked state, only the **OnOff** key can be used to stop the power supply without unlocking. Other operations are locked.

Figure 3-3-4

Explanation of Locked State

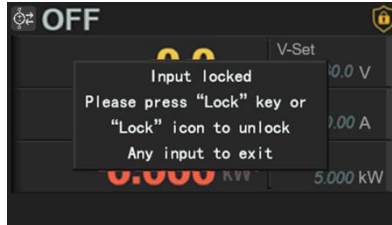

As shown in Figure 3-3-4, tapping the screen while in the locked state will display a brief explanation popup.

The message will disappear automatically after a few seconds, or can be dismissed by tapping again.

To exit the locked state, users can either:

- Press the Lock key, or
- Tap the lock icon in the top-right corner (when the touch function is enabled).

The system will automatically enter the locked state under the following conditions:

- No keypad or touch operation for 5 minutes
- A communication command is received, in which case the unit enters lock mode for 2 seconds (and will not exit the locked state automatically)

Operating Modes: Power Supply and Load

The instrument supports both Power Supply Mode and Load Mode, depending on voltage settings and external conditions.

Power Supply and Sequence Functions

In Power Supply and Sequence functions, only Voltage, Current, and Power parameters can be set.

The Current and Power settings are bidirectional:

- For example, if current is set to 10 A, the system will allow a maximum of +10 A (source) and -10 A (sink).
- Similarly, a power setting of 5 kW allows both +5 kW and -5 kW.

Mode Switching Behavior

When the output voltage of the power supply is higher than the external device, it sources current (Power Supply Mode).

When the output voltage is lower than the external device, the system sinks current (Load Mode).

To directly enter Load Mode, set output voltage to 0 V.

In Battery Simulation and Battery Charge/Discharge functions, the instrument automatically switches between Power Supply Mode and Load Mode based on the configured parameters.

In PV (Photovoltaic) Simulation Mode, the device simulates a solar panel and can operate only in Power Supply Mode.

Dedicated Load Mode

The instrument includes a dedicated Load Mode, with three settable parameters: Resistance, Current, and Power.

In this mode:

- Current and Power settings are unidirectional, meaning they apply only to current sinking (negative current direction).
- For example, a current setting of 10 A allows a maximum negative current of 10 A, with no sourcing capability.

Source mode

Users can configure voltage, positive/negative current, and positive/negative power parameters to start the instrument.

Depending on the load conditions, the system will operate in one of the following control modes:

- CV (Constant Voltage)
- CC (Constant Current)
- CP (Constant Power)

Parameter Control Modes

Two modes are available:

Single Parameter Mode:

Positive and negative current/power share the same absolute value.

Example: Setting current to 10 A applies +10 A and -10 A.

Bidirectional Parameter Mode:

Positive and negative current/power can be set independently.

Source mode interface description

As shown in Figure 3-5-1, the general working mode interface is divided into three areas:

Figure 3-5-1
Source Operating Mode under Standby(OFF)



Figure 3-5-2
Source Operating Mode while Output ON, Constant Voltage Mode with Over Voltage alarm triggered



As shown in Table 3-5-1, the Source Operating Mode Interface is divided into three sections:

Status Display Area

The top bar of the interface displays, from left to right: the power operating mode icon (same as in the menu), output status/ mode icon, alarm indicator (shown when alarm is set to notification mode), and lock status/rotary knob step size.









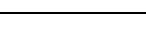

Status area	Icon	Description
Output Indicator		OFF: Output is disabled
		CV: Constant Voltage mode (output maintains a fixed voltage)
		CC: Constant Current mode – output maintains a fixed power
		CP: Constant Power mode – output maintains a fixed power
Alarm Indicator		OV: Over voltage alarm
		LV: Low voltage alarm
		OC: Over current alarm
		LC: Low current alarm
lock status/rotary knob step size		Keybad Locked
		Rotary knob under normal step size.
		Rotary knob under 10 times step size.
		Rotary knob under 100 times step size.

Table 3-5-1 Status icon description

Parameter Setting Area

The center section of the user interface displays measurement and setting values. The left side shows the measured output values of the power supply, while the right side shows the user-defined settings for voltage, current, and power.

- Used to configure the output parameters including Voltage, Positive/Negative Current, and Positive/Negative Power.
- Depending on whether the unit is in Single Parameter Mode or Bidirectional Parameter Mode, the current and power values can be set as symmetric or independently adjustable.



Note

After power-on, the sampling circuit may cause transient disturbances, which can result in measurement fluctuations.

In particular, under no-load conditions, the system may detect a small amount of current, known as leakage current.

To avoid confusion or misinterpretation caused by leakage current, the instrument is equipped with a leakage current masking function.

When the measured current is below the predefined masking threshold, the display will show 0 A.

Therefore, under very light load conditions, it is normal for the current reading to be zero if it is below the masking threshold.

The leakage current masking threshold varies by model and typically ranges from 0.1% to 0.3% of the full scale.

Control Operation Area

In the Control section, each function icon is accompanied by a label in parentheses “()”, indicating that the function can be accessed not only by tapping the touch screen area but also by using the corresponding physical key to switch to the desired mode.

For example, tapping Menu will return to the main menu.

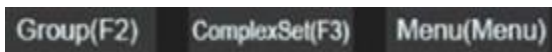

Group function will be activated by F2, CompleSet will be activated by F3

Setting Source Working Mode Parameters

Touch Input for Value Modification

Users can directly tap the corresponding setting area on the screen to bring up the numeric input dialog box (see Figure 3-5-3).

The input dialog will display the parameter name and the valid input range. If an invalid value is entered, an error message will appear.

Within the input interface, the numeric field and the keypad area function similarly (with the exception of the Lock key):

- C key: Clears the input to 0 and resets the entry
- ← (Backspace): Deletes the last digit entered
- Esc key: Cancels the input
- Enter key: Confirms the input

If an input error is indicated, you may use the C key or the backspace key to correct the value, or press Esc to cancel the input.

Figure 3-5-3

Numeric input dialog;
Out-of-Range
Voltage Input
(0.00 - 80.00)



Selecting Parameters via Function Keys

- Press the V-Set function key to select the voltage setting. When selected, a cursor will appear under the voltage value (see Figure 3-5-4). Pressing the key again will deselect the item and remove the cursor.
- Press the I-Set function key to select the current setting. Press again to deselect.
- Press the P-Set function key to select the power setting. Press again to deselect.
- Use the ← or → arrow keys to switch between the voltage, current, and power setting items.
- Press the Esc key to cancel the current selection.

- When an item is selected, pressing the knob (referred to as the knob center key) switches the adjustment resolution of the knob. The current adjustment rate will be indicated by an icon in the upper right corner of the screen.

Figure 3-5-4

Source Mode -
Voltage selected



Modifying Parameters via Keypad / Knob

After selecting the desired parameter, you can adjust its value by turning the knob.

Alternatively, you may press the numeric keys to bring up the value input dialog box (see Figure 3-5-3). After entering the desired value, press the “Enter” key to confirm.



Note

If the output is active (Output On), any adjustment made via the knob or numeric keypad will take effect immediately, enabling real-time parameter control.

Source Mode Operations

Mode	Operation	Effect
Standby/ Output On State	Lock Key	Enter/exit locked status
	V-set Key/Touch voltage setting area	Select voltage setting
	I-Set Key/Touch current setting area	Select current setting
	P-Set Key/Touch power setting area	Select power setting
	← Key or →Key	Switch selected setting
	Esc Key/ Touch non-setting area	Cancel selected setting

Standby	OnOff Key	Power output on
	F2 Key/ Touch "Group" button	Enter Group setting
	F3 key/ Touch "ComplexSet" button	Enter bidirectional parameter setting
	Menu Key/ Touch "Menu" button	Exit to menu interface
Output On State	OnOff Key	Power output off

Table 3-5-2 Source Mode Operations

Source Mode – Output On State

When the power supply is in standby mode, pressing the `On/Off` function key will start the output according to the preset parameters.

If the startup is successful, the indicator light above the `On/Off` key will turn on, and the status bar will display relevant operating information.

If the Soft Start function is enabled in the [Settings → Output] menu and a non-zero ramp-up time is configured, the output voltage will gradually rise after startup until the ramp-up period completes.

During this time, all real-time adjustments, including those via communication commands, will only take effect after the ramp-up process is finished.

The output-on state is shown in Figure 3-5-5, and the operation can be performed in Table 3-5-2.

Figure 3-5-5

Source Operating Mode while Output ON, Constant Voltage Mode



Source Mode – Preset Function

When the power supply is in standby mode, press the `F2` key to access the Preset function.

The system supports up to 10 preset groups, allowing users to quickly recall predefined output configurations for immediate use.

Figure 3-5-6

Preset sub-menu



As shown in Figure 3-5-6, the following operations can be performed in the Preset sub-menu:

- Page Button: Press the “Page” button to quickly switch between preset pages (5 presets per page).
- ← / → Direction Keys: Switch between different selected preset pages.
- F1 Key / Tap “Edit” Button: Enter the edit mode for the currently selected preset.
- F3 Key / Tap “Load & Exit” Button: Load the preset parameters into the current setting values and return to power standby mode.
- F4 Key / Tap “Exit” Button: Exit to power standby mode without loading the preset.
- Menu Key: Enter the main menu to select other operation modes.
- Lock Key: Enter or exit the lock state.

As shown in Figure 3-5-7, the following operations can be performed in the Preset Sub-menu Edit Mode:

Figure 3-5-7

Preset Sub-menu
Edit Mode

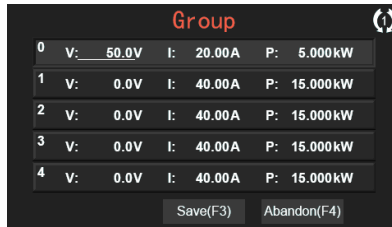

- ← / → Direction Keys: Switch between different selected presets.
- V-Set Function Key: Select or deselect the voltage setting of the preset.
- I-Set Function Key: Select or deselect the current setting of the preset.
- P-Set Function Key: Select or deselect the power setting of the preset.
- F3 Key / Tap “Save” Button: Save the current changes and return to the Preset Sub-menu Status.
- F4 Key / Tap “Exit” Button: Discard changes and return to the Preset Sub-menu Status.
- Tap parameter / Select parameter and press numeric keys: Open a numeric input dialog box.
- After selecting a parameter: Use the knob to adjust the value directly.
- Knob Center Button: Adjust the knob control rate.
- Menu Key: Enter the main menu to select other operating modes.
- Lock Key: Enter or exit the lock state.

Bidirectional Parameter Mode

In certain use cases, where switching between positive and negative current/power is required – and the positive and negative values are not equal – the Bidirectional Parameter Mode can be activated.

While in Power Mode, press the F3 key to enter Bidirectional Parameter Mode. This mode functions similarly to the standard

power mode, with the following differences:

- The current and power parameters are split into:
 - Positive Current / Positive Power
 - Negative Current / Negative Power
- This allows independent setting of forward and reverse output parameters to meet bidirectional application requirements.

The standby and operating status screens for this mode are illustrated below:

Bidirectional Parameter Mode – Standby Status

As shown in Figure 3-5-8, the following operations can be performed in the standby status of the Bidirectional Parameter Mode:

- ← / → Direction Keys: Switch between different parameter settings.
- V-Set Function Key: Select or deselect the voltage setting.
- I-Set Function Key: Select or deselect the positive and negative current settings.
- P-Set Function Key: Select or deselect the positive and negative power settings.
- F3 Key / Tap “SingleSet(F3)” Button: Exit Bidirectional Mode and return to the standard source mode.
- Menu Key: Enter the menu to select other operating modes.

Figure 3-5-8

Bidirectional
Parameter Mode
— Operating
Status

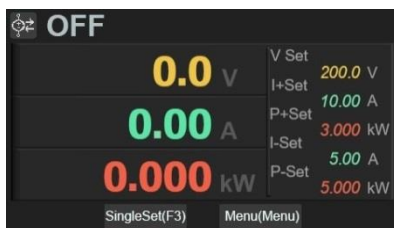

Figure 3-5-9

Bidirectional
Parameter Mode
— Standby Status



Bidirectional Parameter Mode — Operating Status

As shown in Figure 3-5-9, the following operations can be performed in the Operating status of the Bidirectional Parameter Mode:

- ← / → Direction Keys: Switch between different parameter settings.
- V-Set Function Key: Select or deselect the voltage setting.
- I-Set Function Key: Select or deselect the positive and negative current settings.
- P-Set Function Key: Select or deselect the positive and negative power settings.

Sequence Mode (Seq. Mode)

The Sequence Mode allows users to configure a series of parameters – such as voltage/voltage transitions, current/current transitions, power settings, operation types, and time duration – and output them automatically according to the defined sequence steps. This mode is ideal for automated testing and aging test applications.

- Up to 50 sequences can be stored (Sequence No. 0 to 49).
- Each sequence can contain up to 20 steps (Step No. 0 to 19).
- Each step can be configured independently with functions such as:
 - Enable switch
 - Loop execution
 - Slew rate output mode

Sequence Test — Standby Status

From the main menu screen, press the F2 key to enter the main Sequence Test interface.

1. Menu
2. Seq. (F2)

The interface layout is similar to Power Mode. The parameter setting area shows the currently selected Sequence number. As shown in Figure 3-6-1, the following operations are available in the Sequence Test standby status:

- On/Off Key: Start sequence output of the power supply.
- ← / → Direction Keys: Select different sequence numbers.
- F2 Key / Tap "One Step" Button: Start single-step sequence output (pauses automatically after each step for manual operation).
- F3 Key / Tap "Edit" Button: Edit parameters for the selected Sequence.
- Menu Key: Enter the menu to select other operating modes.

Figure 3-6-1

Sequence Standby Interface



Sequence Test — Sequence Test Browser

From the Sequence Test Standby interface, press the F3 key or tap the “Edit” button to enter the Sequence Browser interface, as shown in Figure 3-6-2.

Figure 3-6-2

Sequence Browser interface

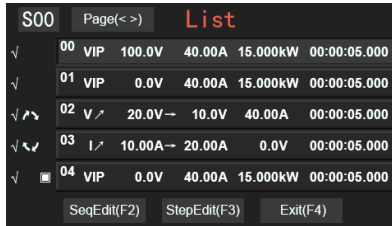

The symbols shown in the earlier columns correspond to step parameters, as defined in Table 3-6-1. For a detailed definition of step parameters, please refer to Table 3-6-2.

Position	Symbol	Description
First column		Current Step: Enabled
		Current Step: Pause after run
		Current Step: Disabled
Second column		Loop Setting: Loop Start Step
		Loop Setting: Loop End Step
Third column		Operation: Stop
		Operation: Jump to Sequence
		Opera: Next step

Table 3-6-1 Symbol Definitions in Sequence Browser Interface

Operations in the Sequence Browser Interface:

- Tap the “Sxx” Button (where xx is the current sequence number) to open the numeric input dialog. Enter a new number and press Enter to switch sequence .
- Tap the “Page” Button to quickly switch between step pages (5 steps per page).
- Use the ← / → Direction Keys to navigate between steps in the current sequence .
- F2 Key / Tap “Sequence Edit” Button: Quickly perform step operations, such as cut and insert.
- F3 Key / Tap "Step Edit" Button: Enter the step edit interface to modify parameters of the selected step.
- F4 Key / Tap "Exit" Button: Return to the Sequence Test Standby state.
- Menu Key: Enter the menu to select other operating modes.
- Lock Key: Enter or exit the lock state.

Sequence Test — Sequence Edit

From the Sequence Browser Interface, press the F2 key or tap the “Sequence Edit” button to enter the Sequence Edit Interface, as shown in Figure 3-6-3.

Figure 3-6-3

Sequences edit interface

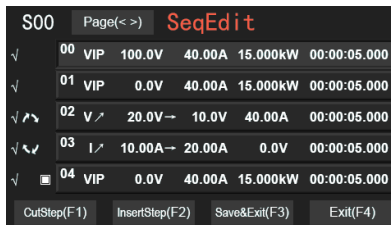

The following operations can be performed in the Sequence Edit Interface:

- Tap the “Page” button to quickly switch between step pages (5 steps per page).
- Use the ← / → Direction Keys to navigate among steps within the

current Sequence.

- F1 Key/ Tap "Cut Step" Button: Delete the current step, shift subsequent steps forward, and store the deleted step in the Sequence Edit Clipboard for insertion use.
- F2 Key / Tap "Insert Step" Button:
If the clipboard is empty, a new default step is inserted.
If the clipboard contains a step, that step is inserted, and the current and following steps are shifted backward.



Note

The clipboard will be cleared each time you enter the sequence Edit mode.

- F3 Key / Tap "Save & Exit" Button: Save all modifications to the current Sequence and return to the Sequence Browser.
- F4 Key / Tap "Exit" Button: Discard all modifications and return to the Sequence Browser.
- Menu Key: Enter the menu to select other operating modes.
- Lock Key: Enter or exit the lock state.

Sequence Test — Step Edit

From the Sequence Browser Interface, press the F3 key or tap the "Step Edit" button to enter the Step Edit Interface, as shown in Figure 3-6-4.

Figure 3-6-4

Step Edit
Interface



Available Operations

- Tap "Soo-xx" (xx: current step number) to enter a new step number. Press Enter to switch to the specified step.
- Use the ← / → Direction keys to switch between editable parameters (see Table 3-6-2).

- F3 key / Tap “Save & Exit”: Save all modifications and return to the Sequence Browser.
- F4 key / Tap “Exit”: Discard all modifications and return to the Sequence Browser.
- Menu key: Enter the menu to select another operation mode.
- Lock key: Enter or exit the lock state.

Mode	VIP: Outputs the configured voltage, current, and power for the defined duration.	Vramp: Voltage ramps from the start value (V1) to the end value (V2) within the specified time.	I ramp: Current ramps from the start value (I1) to the end value (I2) within the specified time.
Parameter1	Vset: voltage setting	V1set: start voltage	I1set: start current
Parameter2	Iset: current setting	V2set: end voltage	I2set: end current
Parameter3	Pset: power setting	Iset: current setting	Vset: voltage setting
Time	Range: 0.01 sec to 99 hour 59 min 59.999 sec		
Enable	Enable: Normal step is performed Run pause: Pause the sequence after executing the current step (to maintain output with the termination value) Disable: The current step is skipped during execution		
Loop Set	Normal: Executes the current step normally Loop begin: Loop executes the start of loop step of the current step Loop end: Loops the loop termination step of the current step Note 1: A loop needs to be paired with a begin and an end, and cannot be looped if only the loop a begin or an end Note 2: The loop can execute the loop sequentially, only single-layer loops are supported, and single does not support nested loops Note 3: The number of loops set to 0 or 1 is actually equivalent to no loops. Note 4: Loops are valid only within a single sequence, and the begin of one sequence loop and the end of another sequence loop cannot be paired		
Loop Cnt	Range: 0~9999		

Operation	Next: After the current step is executed, the sequence output stops when there is no further step Stop: Stop sequence output after executing the current step JumpSeq.: Jump to step 0 of the other sequence after executing the current step
Jump Seq.	Range: 0~49

Table 3-6-2 Sequence step parameter description



Note

In V Ramp or I Ramp mode, the Pset (power setting) corresponds to the maximum rated power of the power supply.

Sequence Test — Run Mode

From the Sequence Test Standby Interface, press the OnOff key to start executing the configured steps in the selected sequence. The power supply enters the Sequence Run Interface, as shown in Figure 3-6-5.

Figure 3-6-5

Sequence Run Interface



Available Operations in Run Mode

- OnOff Key: Stop sequence output and return to standby mode.
- F1 Key / Tap “Pause” Button: Pause the sequence timer and hold the output at the current step values.
- Lock Key: Enter or exit the locked state.

Sequence Test — Pause

From the Sequence Run Interface, press the F1 key or tap the “Pause” button to enter the Sequence Pause Interface.

When running in Single Step mode, the sequence pauses after each step.

Sequence routine starts, and when the “enable” parameter is set to “Run&Pause”, the list is automatically suspended when the step is performed.

Figure 3-6-6

Sequence Pause Interface

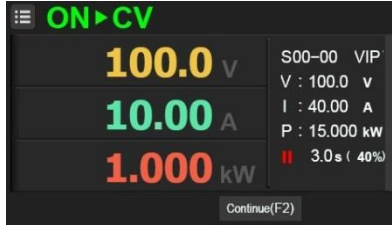

Available Operations in Pause Mode

- OnOff Key: Stop the sequence output and return to standby mode.
- F2 Key / Tap "Continue" Button: Resume sequence execution.
- If the remaining time of the current step is 0 (e.g., in single-step mode or when the step is set to “Run&Pause”), the system will proceed to the next executable step.
- Lock Key: Enter or exit the locked state.

Sequence Test — Single Step Operation

From the Sequence Run Interface, press the F2 key or tap the “OneStep” button to start executing each configured step of the selected sequence one at a time.

After each step is completed, the power supply will automatically pause and maintain the output values. At this point, the following actions are available:

Press the F2 key or tap the “Continue” button to continue to the next step.

Press the OnOff key to stop the sequence output and return to standby mode.

Sequence Test — Example Configurations

Sequence 1: Voltage Waveform Test

As shown in Figure 3-6-7, Sequence 1 generates a voltage waveform.

The current and power settings are configured to the device's maximum allowable current and power levels.

Figure 3-6-7

Example
Waveform for
Sequence 1

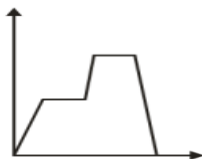

No.	Mode	Para1	Para2	Para3	Time	Enable	Loop Set	Operation
0	V ramp	0 V	40 V	510 A	2 s	Enable	Normal	Next
1	VIP	40 V	510 A	15 kW	3 s	Enable	Normal	Next
2	V ramp	40 V	70 V	510 A	1 s	Enable	Normal	Next
3	VIP	70 V	510 A	15 kW	3 s	Enable	Normal	Next
4	V ramp	70 V	0 V	510 A	2 s	Enable	Normal	Stop

Table 3-6-3 Step Settings for Sequence 1

Sequence 2: Burn-in Profile for Electronic Device

This sequence is designed to meet the test requirement of the following profile:

50 V for 4 s, then 0 V for 2 s, repeated for 30 minutes.

Followed by 60 V for 10 minutes burn-in.

To achieve this pattern:

Use loop control with a 6-second cycle time (4 s + 2 s).

For a 30-minute duration, set the loop to run 300 times.

No.	Mode	Para1	Para2	Para3	Time	Enable	Loop Set	Loop Cnt	Operation
0	VIP	50 V	510 A	15 kW	4 s	Enable	Loop begin	300	Next
1	VIP	0 V	0 A	0 kW	2 s	Enable	Loop end	0	Next
2	VIP	60 V	510 A	15 kw	10 m	Enable	Normal	0	Stop

Table 3-6-4 Step Settings for Sequence 2

Photovoltaic (PV) Mode

Certain power supplies with output voltage 500 V and above come standard with the Photovoltaic (PV) Mode.

The PV Mode allows the power supply to simulate a solar panel or panel array (via a host computer) for testing the characteristics and performance of photovoltaic inverters. The host computer can further simulate various complex scenarios such as standard static MPPT tests, dynamic MPPT tests, cloud shading, moving clouds, and weather simulation.

PV Standby State

The current output voltage is displayed at the bottom-right corner of the PV standby interface. When output is stopped, the power supply discharges internally at a slow rate.



Some PV inverters cannot start properly at medium or low voltage levels, which may cause startup errors. Therefore, it is recommended to start the PV mode only when the output voltage is near zero or at a low level.

Stability Notice

Due to differences among PV inverter manufacturers, some PV inverters may experience unstable operation. Please refer to the PV Settings section to configure parameters accordingly. If issues persist, please contact the power supply manufacturer for support.

PV IV Mode Description

The power supply's PV Mode supports photovoltaic array simulation with a built-in EN50530 standard IV model to emulate the I-V output curve of a PV array.

Key parameters:

Voc: Open-circuit voltage

Isc: Short-circuit current

Vmp: Voltage at maximum power point

Imp: Current at maximum power point

The typical output curve is shown below:

Figure 3-7-1
PV Mode I-V
Output Curve

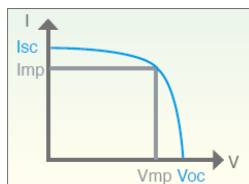

In addition, due to the factors of the model formula, the V_{mp} and I_{mp} input by the user will be different from the V_{mp} and I_{mp} obtained by the formula, and the difference will be greater when the filling factor is smaller.

Instructions:

1. Fill factor (FF) definition: $FF = \frac{V_{mp}}{V_{oc}} \times \frac{I_{mp}}{I_{sc}}$;
2. V_{oc} , I_{sc} , V_{mp} , I_{mp} parameter setting limits:
 - $V_{max} \geq V_{oc} > V_{mp} > 0$
 - $I_{max} \geq I_{sc} > I_{mp} > 0$
 - $\frac{V_{mp}}{V_{oc}} > 1 - \frac{I_{mp}}{I_{sc}}$
 - $P_{max} \geq P_{mp} = V_{mp} \times I_{mp} > 0$

V_{max} , I_{max} , and P_{max} indicate the upper limit of voltage, current, and power (you can change them on the setting screen).

When the parameters V_{oc} , I_{sc} , V_{mp} , or I_{mp} , calculated under the SAS mode direct setting or EN50530 standard model exceed these limits, a yellow warning icon flashes at the upper-right corner of the standby interface.

Touching the warning will display the error prompt screen as shown below:

Figure 3-7-2

PV Setting Error
Warning Interface

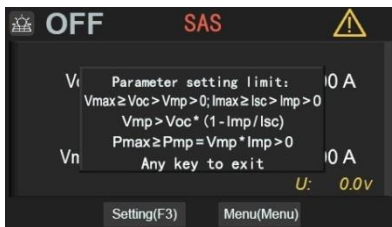

PV SAS Standby Mode

When the power supply supports Photovoltaic (PV) Mode, press the F3 key from the Menu Interface to enter the PV SAS Standby Interface, provided that the PV model selected in the PV Settings Menu is set to SAS Model.

In this interface, you can configure four key SAS parameters:

Voc: Open-Circuit Voltage

Vmp: Voltage at Maximum Power Point

Isc: Short-Circuit Current

Imp: Current at Maximum Power Point

For definitions of these parameters, refer to section PV I-V Mode Description.

Figure 3-7-3

PV SAS Standby
Interface



PV SAS Standby Interface as shown in Figure 3-7-3, you can perform the following operations:

- OnOff Function Key: Start the power photovoltaic function
- ← or → Function Key: Select Set parameters: Voc, Vmp, Isc, Imp
- V-set Function Key: Quickly switch between Voc/ Vmp/ uncheck
- I-Set Function Key: Quickly switch between Isc/ Imp/ uncheck
- F3 Function Key: Enter the PV setting mode

- Menu Function Key: Return to the menu to select another operating mode.
- Lock Function Key: Enter or exit the locked state.

PV EN50530 Standby Mode

When the power supply supports Photovoltaic (PV) Mode, press the F3 key in the Menu Interface. If the selected PV model (configured in the PV Settings menu) is EN50530, the system will enter the PV EN50530 Standby Interface.

In this mode, four EN50530 parameters can be configured. The parameter definitions are listed in Table 3-7-1.

Page	Item	Item Type	Description
PV	Irr	Numerical	Irradiance (W/m ²), range: 0-3000
EN50530 Standby interface	Vmp	Numerical	Voltage at maximum power point (see Vmp in PV IV Mode Description)
	Pmp	Numerical	Maximum power point (Pmp = Vmp × Imp), see PV IV Mode Description
	FF	Options	Fill Factor type: cSi (Crystalline Silicon), TF (Thin-Film)

Table 3-7-1 EN50530 Parameter Definitions

Photovoltaic EN50530 ready interface as shown in Figure 3-7-4, you can perform the following operations:

- OnOff Key: Start PV output.
- ← / → Direction Keys: Navigate between editable parameters: Irr, Vmp, Pmp, FF.
- V-Set Function Key: Toggle selection of Vmp.
- P-Set Function Key: Toggle selection of Pmp.
- F3 Key: Enter PV Settings Mode.
- Menu Key: Return to the main menu to select a different operating mode.
- Lock Key: Enter or exit the locked state.

Figure 3-7-4

PV EN50530
Standby Interface



PV Sandia Standby Mode

When the power supply supports Photovoltaic (PV) Mode, press the F3 key from the Menu Interface. If the selected PV model (configured in the PV Settings menu) is set to Sandia, the system will enter the PV Sandia Standby Interface.

In this interface, you can configure seven Sandia PV parameters as defined in Table 3-7-2.

Page	Item	Item Type	Description
Sandia ready interface	Irr	Numerical	Irradiation, unit: W/m ² , range: 0 to 3000
	IrrREF	Numerical	Reference irradiation, unit: W/m ² , range: 0 to 3000, default: 1000
	TC	Numerical	Temperature, unit: °C, range: -40 to 85
	TREF	Numerical	Reference temperature, unit: °C, range: -40 to 85, default: 25
	Vmp	Numerical	Voltage at maximum power point (see Vmp in PV IV Mode Description)
	Pmp	Numerical	Maximum power point (Pmp = Vmp × Imp), see PV IV Mode Description
	FF	Options	Fill Factor type: TF: Thin-Film SCMC: Standard Crystalline or Multi-crystalline HEC: High-efficiency Crystalline

Table 3-7-2 Description of PV Sandia Settings

Photovoltaic Sandia ready interface as shown in Figure 3-7-5, you can perform the following operations:

- OnOff Key: Start PV output.
- ← / → Direction Keys: Navigate between editable parameters (Irr, IrrREF, TC, TREF, Vmp, Pmp, FF)
- V-Set Function Key: Toggle selection of Vmp
- P-Set Function Key: Toggle selection of Pmp
- F3 Key: Enter PV Settings Mode
- Menu Key: Return to the menu to select another operating mode
- Lock Key: Enter or exit the locked state

Figure 3-7-5

PV Sandia
Standby interface



PV SAS2 Standby mode

Due to the limitations of the EN50530 and Sandia models, where the Fill Factor (FF) is defined as a fixed type according to standard requirements, they may no longer meet the needs of newer or more flexible devices. To address this, the SAS2 Model has been introduced. It extends FF from a fixed type to a configurable numeric range, enabling broader compatibility for various device testing needs.

When the power supply supports Photovoltaic (PV) Mode, press the F3 key from the Menu Interface. If the selected PV model is SAS2, the system will enter the PV SAS2 Standby Interface, where five PV parameters can be configured. Table 3-7-3 defines the parameters as follows:

Page	Item	Item Type	Description
PAS2 ready interface	Irr	Numerical	Irradiation, unit: W/m ² , range: 0 to 3000
	TC	Numerical	Temperature, unit: °C, range: -40 to 85
	FF	Numerical	Range:0.40 to 0.95
	Vmp	Numerical	Voltage at maximum power point (see Vmp in

			PV IV Mode Description)
	Pmp	Numerical	Maximum power point (Pmp = Vmp × Imp), see PV IV Mode Description

Table 3-7-3 Description of PV SAS2 Settings

Photovoltaic SAS2 ready interface as shown in Figure 3-7-6, you can perform the following operations:

- OnOff Key: Start PV output.
- ← / → Direction Keys: Navigate through editable parameters (Irr, TC, FF, Vmp, Pmp)
- V-Set Function Key: Toggle selection of Vmp
- P-Set Function Key: Toggle selection of Pmp
- F3 Key: Enter PV Settings Mode
- Menu Key: Return to the main menu to select another operating mode
- Lock Key: Enter or exit the locked state

Figure 3-7-6

PV SAS2 ready interface



PV Setting

Under the PV ready interface, press **F3** key to enter the PV setting interface, as shown in Figure 3-7-7, and the contents are shown in Table 3-7-4:

Page	Item	Item Type	Description
PV Setting	IV Model	Options	SAS: Custom PV curve based on the EN50530 standard IV model, allows user-defined settings of Voc, Vmp, Isc, and Imp. EN50530: Complies with the EN50530 standard, supports configuration of Irr, Vmp, Pmp, and FF.

			<p>Sandia: Based on the Sandia standard, supports settings for Irr, IrrRef, TC, TREF, Vmp, Pmp, and FF.</p> <p>Table: Host-PC controlled operating mode. Local (front panel) configuration is not available.</p> <p>SAS2: An extended model based on Sandia, allows numeric FF values for more flexible device testing.</p>
	Search Mode	Options	Operating control for IV curve mode: CC (Constant Current), CV (Constant Voltage)
	Filter	Numerical	Range: 0–3125 Hz; input filter frequency for sampling. 0 means no filtering
	Speed	Numerical	Range: 1–200; affects speed of IV curve output.
	Margin	Numerical	Range: 1–200; affects speed of IV curve output.

Table 3-7-3 PV Settings

Factory Default Values:

Operation Mode: CC

Sampling Filter: 0 Hz

Output Rate: 2

Headroom Margin: 5%

These default settings are sufficient for most PV inverters.

Due to variations in internal MPPT algorithms among different PV devices, IV tracking response behavior may differ. It is recommended to fine-tune the following parameters based on your PV device:

Switch Operation Mode between CC / CV

Adjust Output Rate between 2 to 20

Set Headroom Margin between 5% to 20%

These parameters can be combined and tuned to optimize compatibility with different PV inverters.

If the PV device experiences interference on either the AC or DC side, you may reduce the influence by configuring the Sampling Filter. A typical value for filtering is 1000 Hz.

Figure 3-7-7

PV Setting

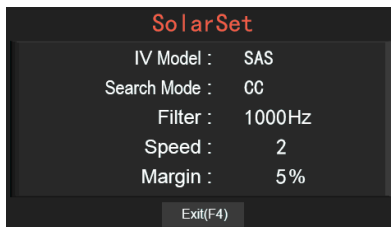

PV Settings interface, you can perform the following operations:

- ← / → Direction Keys: Navigate between parameters
- When a parameter is selected:
 - Tap the value field or use numeric keys to open the numeric input dialog
 - Use the knob to adjust the value directly
 - Press the knob center button to change adjustment step size
- F4 Key: Exit the PV Settings interface and return to the corresponding PV Standby Interface (depending on the selected PV model)
- Lock Key: Enter or exit the locked state

PV mode - Running

From the PV Standby Interface, press the OnOff key to start PV output. The system will enter the PV Operation Interface, as shown in Figure 3-7-8. The display and behavior depend on the PV Curve Output Mode configured in the PV Settings Page (see page 8). If the Soft Start Time is configured to a non-zero value in the Output Settings, the output voltage will gradually ramp up during the soft start duration. During this ramp-up period, all live parameter adjustments, including remote communication commands, will only take effect after the soft start completes.



“Curve”

“Non-Curve Modes”

Figure 3-7-8 PV Operation Interface (Curve and Non-Curve Modes)

The Curve mode can be enabled or disabled through the Solar Run Curve option on Setting Page 8. (Menu -> Setting -> page 8 -> Solar Run Curve)

The PV Operation Interface is shown in Figure 3-7-8, and the following actions are available:

- OnOff Key: Stop PV output.
- F2 Key: Refresh the display curve. (Use this function when image artifacts appear due to large data transfer or interference from downstream PV devices.)
- F3 Key: Enter Online Adjustment Mode.
- Lock Key: Enter or exit the locked state

PV mode - online adjustment

When the PV model is set to any mode other than Table, pressing the F3 Key in the PV Operation Interface allows access to the Online Adjustment Interface. This interface is similar in layout to its corresponding standby screen.

Figure 3-7-9

SAS2 Online Adjustment Interface



The PV operation online adjustment interface is shown in Figure 3-7-9, and the following operations can be performed:

- OnOff Key: Stop PV output.
- F3 Key: Enter Online Adjustment again (Note: This button may disappear if parameter conditions are invalid).
- F4 Key: Discard changes and return to the main PV Operation Interface.
- Lock Key: Enter or exit the locked state.

Settings Overview

In the setting interface, you can set communication parameters, alarm parameters, limit parameters, system parameters, operating parameters and so on.

List of Setting Parameters

Top Section: Displays the parameter category.

Right Corner: Shows the current page and total number of pages (e.g., Page 1/3).

Middle Section: Lists all available parameters in that category.

Bottom Section: Contains navigation keys such as "Next Page" and "Return".

Figure 3-8-1
Setting - Protocol
Interface



All Settings parameters can be performed:

- ← / → Direction Keys : Navigate through the selectable parameters on the current page. See Table 3-8-1 for parameter details.
- F2 Key / "Previous Page" Button: Switch to the previous parameter page.
- F3 Key / "Next Page" Button: Switch to the next parameter page.
- Menu Key: Return to the main menu to select other operating modes.
- Lock Key: Enter or exit the lock state.

How to Modify Parameters

Numeric Parameters:

Tap the value or press a key to open the numeric input dialog. You can also select the value and use the knob to adjust it.

Option Parameters:

Tap to toggle through options, or select and adjust using the knob.

Display-Only Parameters:

These are read-only values used for monitoring. Editing is not allowed.

Sub-pages:

Parameters ending with “...” lead to additional configuration screens. Press to enter the sub-page.

No.	Page	Item	Item Type	Description
1	Protocol (not CAN interface)	Protocol	Options	RBS, SCPI, ModbusRTU, ModbusTCP and other protocol
		Pro.Adr	Numerical	Range:1 to 250, only RBS/ ModbusRTU/ ModbusTCP is effective
		Add LF	Options	Yes/No, only the SCPI protocol is valid, append line feed sign 0x0A when returning
		Version	Display	Prompt software control/display software version
	Protocol (CAN interface)	Protocol	Display	The CAN communication protocol J1939 is optional. If necessary, please request a protocol table explanation from the manufacturer.
		DC Adr	Numerical	Range: 1 to 250
		Remote Adr.	Numerical	Range: 1 to 250, Cannot be set to the same address as DC Adr. If set to the same address, it will be automatically changed
		Version	Display	Prompt software control/display software version

2	Interface (RS232/ RS485/ USB)	Interface	Options/ Display	RS232/RS485/ USB Communication interface, display if only one interface, options if two or more interfaces.	
		Baud rate	Options	9600/19200/38400	
	Interface (optional: LAN)	Interface	Options/ Display	LAN Communication interface, display if only one interface, options if two or more interfaces.	
		LAN mode	Display	TCP Server	
		DHCP	Options	On/Off, The connected router must support DHCP; otherwise, the router cannot work properly. When this mode is on, you cannot connect to the computer directly.	
		IP Address	Numerical	IP4 format	
		Mask	Numerical	IP4 format	
		Gateway	Numerical	IP4 format	
		Port	Numerical	Range :1 to 65535	
	Interface (optional: CAN)	Interface	Options/ Display	LAN Communication interface, display if only one interface, options if two or more interfaces.	
		Baud rate	Options	100 k/125 k/250 k/500 k	
	3	Vol alarm	OVP	Numerical	Voltage Output Upper limit Hardware protection value, used to protect the user's load. The threshold should be set to the maximum protection value that the load can withstand without damage. Once triggered, immediately stop the output and enter the alarm interface; Range : 1 V to 1.1 times the upper voltage limit of the power
			Vol Up	Numerical	Voltage output upper limit Software protection value. The alarm is valid in ready mode, and the alarm and

				tip are valid in running mode Range :0 to 1.1 times the upper voltage limit of the power
		Vol Down	Numerical	Voltage output lower limit Software protection value. It takes effect only after the running state runs for 1 second (1 second + start slow up time if there is a start slow up) Range: 0 to 1 times the upper voltage limit of the power
		Up Alarm Time	Numerical	Upper voltage duration, when the power output continuously exceeds this setting, the software protection can be triggered Range: 0 to 99.999 seconds
		Down Alarm Time	Numerical	Lower voltage duration, when the power output is continuously below this setting, the software protection can be triggered Range: 0 to 99.999 seconds
		Up Alarm	Options	When the power supply starts, the software protection is triggered, and the power supply action is: Alarm: The power supply stops output and enters the alarm state Tip: The power output is maintained and a prompt is displayed in the status bar None: No action is performed
		Down Alarm	Options	Alarm/Tip/None
4	Cur Alarm	Cur Up	Numerical	Current output upper limit Software protection value. Valid only in running mode Range: 0 to 1.1 times the upper voltage limit of the power
		Cur Down	Numerical	Current output lower limit Software protection value. It takes effect only after the running state runs for 1 second (1 second + start slow up

				time if there is a start slow up) Range: 0 to 1 times the upper voltage limit of the power
		Up Alarm Time	Numerical	Upper current duration, when the power output continuously exceeds this setting, the software protection can be triggered Range: 0 to 99.999 seconds
		Down Alarm Time	Numerical	Lower current duration, when the power output is continuously below this setting, the software protection can be triggered Range: 0 to 99.999 seconds
		Up Alarm	Options	Alarm/Tip/None
		Down Alarm	Options	Alarm/Tip/None
5	Range	Vol Max	Numerical	Upper limit of the range when the power operating voltage is set. Range: 0 to 1 times the upper voltage limit of the power
		Vol Min	Numerical	Lower limit of the range when the power supply operating voltage is set. Range: 0 to 1 times the upper voltage limit of the power
		Cur Max	Numerical	Upper limit of the range when the power supply operating current is set. Range: 0 to 1 times the upper current limit of the power
		Cur Min	Numerical	Lower limit of the range when the power supply operating current is set. Range: 0 to 1 times the upper current limit of the power
		Pow Max	Numerical	Upper limit of the operating power range. Range: 0 to 1 Power upper limit of the power
6	System	Online set	Options	Single/ Master/ Slave, set the parallel state.
		Online	Numerical	Used to set the number in parallel

		quantity		Range: 1 to model Maximum number of parallel machines
		Online current adjust	Numerical	When the parallel combination changes, the on-line current will have a certain offset, you can correct the current value after the parallel change by using this option.
		Time	Sub page	The date and time setting page is displayed
		Black box	Sub page	The alarm black box page is displayed
		Factory Data Reset	Sub page	The confirm or cancel dialog box is displayed
7	Operation	Language	Options	Options: Chinese /English
		Touch Enable	Options	Whether the LCD touch function is enabled Options: On/Off
		Key Sound	Options	Whether a prompt tone is played for key or touch operations Options: Yes/No
		Alarm Sound	Options	Whether the alarm interface emits an alarm sound Options: Yes/No
		Auto Screen Off	Options	Whether to automatically turn off the LCD backlight brightness if no operation is performed for a long time Options: Yes/No
		Brightness	Numerical	Range: 5 to 63
		Auto Lock	Numerical	Automatic key lock time, unit: minute. If no operation (key/touch/knob) is performed within the set time, the key lock state will be automatically entered. 0 indicates that the automatic key lock function is disabled Range: 0 min. to 60 min.

8	Output	Soft Rise	Numerical	Source state and photovoltaic state starting voltage soft rise start Range: 0.0 to 99.9 second
		Solar Run Curve	Options	Whether the curve displays state when the photovoltaic is running, the curve display state will be stuck due to the large amount of data when transmitting and refreshing the interface. If you mind, please close it. Option: On/off

Table 3-8-1 List of Setting Parameters

OVP alarm and voltage upper limit alarm difference:

(1) OVP Alarm

- Triggered by hardware over-voltage protection.
- Once triggered, output is immediately stopped.
- The system enters an alarm state and shuts off all main power switches.

(2) Voltage Upper Limit Alarm

- Triggered by software over-voltage monitoring.
- If the alarm mode is set to “Prompt,” and the output voltage exceeds the upper limit for longer than the configured alarm duration, the power supply continues normal output but displays an alarm message in the status bar.
- When the output voltage drops below the upper limit, the alarm prompt automatically clears.

Figure 3-8-2 shows the working process of the voltage upper limit alarm

Figure 3-8-2

Illustrates the operation process of the voltage upper limit alarm

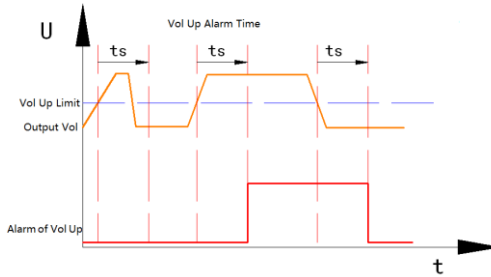

Time Setting

The LCD displays the current time in the lower right or upper left corner of some interfaces. If the time is not accurate, please enter the time setting interface to correct the time.

On the system interface, click “...” next to the time option. The time setting interface is displayed.

Figure 3-8-3

Time setting interface



Time setting interface as shown in Figure 3-8-3, you can perform the following operations:

- ← or → Direction keys to switch the selected item on the current page;
- F2 key / tap “Modify Time” button to set the current time to the displayed setting;
- F4 key / tap “Exit” button to return to the System Settings menu;
- Menu key to enter the main menu for selecting other operating modes;
- Lock key to enter/exit lock state.

Viewing the Black Box

The power supply provides 50 black box records. When an alarm occurs (the alarm tip is not recorded), the power supply records the alarm time and power status information in the black box, facilitating power supply repair and maintenance.

When there are more than 50 power records, the oldest record will be deleted and used to record the latest entry.

On the system interface, click “...” next to the black Box option. The black box page is displayed.

Figure 3-8-4 shows the black box interface. The layout is described as follows:

The title is on the top, and the message “Black box browsing number/Total number of black box records” is on the right.

The middle is the parameter content, the top behavior alarm code and alarm information, the second behavior alarm time page code and power setting parameters, the third behavior alarm time power output status information, the next behavior alarm time;

At the bottom are clear, item switch and return buttons;

Figure 3-8-4

The black box interface

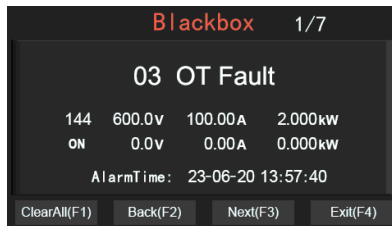

On the black box interface, you can perform the following operations:

- F1 function key, Touch the “ClearAll” button to delete all black box records.
- F2 Function Key, Touch the “Back” button to view the previous black box record.
- F3 Function Key, Touch the “Next” button to view the next black box record.

- F4 Function Key, Touch “Exit” button to return to setting interface
- Menu Function Key, Enter the menu to select other working modes.
- Lock Function Key, Enter or exit the locked state.

Network Port Settings (Optional)

Figure 3-8-5

Network Port
Settings interface

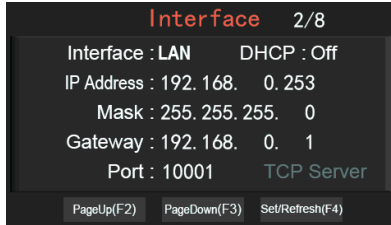

When selecting network ports, you can set DHCP, IP address, and port number on the panel.



Note

Some legacy versions of the network port cannot be configured via the panel and require upper-level computer software for setting.

Because the network port is an independent module, there is a delay of 1 to 5 seconds between reading network port parameters and setting network port parameters.

In this interface, after modifying parameters such as DHCP, IP, and port number, you need to press F4 or the Set/Refresh button of the corresponding screen area to make the new network port Settings take effect. If you press F4 to set/refresh after modification, the setting data will be lost after switching to another interface. After returning to this interface, the power supply will read the setting data of the network port module again.

Set DHCP to enable. After the setting is complete, it takes a certain period of time (5 to 30 seconds depending on the router). Press the F4 key to refresh parameters such as the IP address after auto-negotiation. Note that the DHCP function is required for the router to work properly. If the router is directly connected to the computer or does not have the DHCP function, the IP address will always be read as 0.0.0.0.

To ensure reliability, the network port works in TCP server. When connecting the network port through a PC, set the working mode of

the PC to TCP client. If parameters such as the IP address are changed and the module is successfully modified, it takes 5 to 20 seconds for the computer to find the new IP address and port number based on the connection mode or router.

**Note**

1. If a large number of devices on a router have the DHCP function, the IP addresses of the router may be changed if the power-on sequence or devices are changed.
 2. When you enter the network port setting screen, the DHCP function is gray and cannot be changed. Refresh the system or power it on again. If the system still fails to work after multiple attempts, contact the supplier or power supply manufacturer.
-

Battery simulation mode

The power supply can simulate real battery characteristics, including charge and discharge behavior, assisting with various tests.

It includes nearly 10 built-in battery models based on international papers and experimental data:

lithium manganate LMO

lithium cobaltate LCO

lithium iron phosphate LFO

terpolymer lithium NCM

lithium titanate LTO

lead-acid battery Pb

nickel-metal hydride battery NiMH

nickel-cadmium battery NiCd.

Users can also customize battery parameters for simulation.

Battery Simulation Standby and Parameter Interface

Enter the battery simulation standby by pressing key 1 or touching the battery icon in the menu.

The external voltage is displayed at the bottom right.

There are 3 parameter pages:

Battery Parameters (Fixed models or Custom)(Figure 3-9-1 or 3-9-2)

Running Parameters(Figure 3-9-3)

SoC Parameters(Figure 3-9-4)

The battery parameters interface is divided into fixed battery and custom battery. You can switch by tapping the battery type. The main difference is that the V-Soc curve model of the fixed battery is built into the power supply; The customized battery needs to input node Soc curve parameters, and then the power supply fills the middle.

Battery simulation ready interface as shown in Figure 3-9-1/3-9-2, you can perform the following operations:

- OnOff key: Start battery simulation output
- F2 / touch “Run Set”: enter running parameters
- If “Battery Type” is Custom, F3 / touch “SoC” enters SoC parameters
- Menu key: switch modes
- Lock key: lock/unlock

Figure 3-9-1

Battery parameters interface - fixed battery



Figure 3-9-2

Battery parameters interface - custom battery



On the battery parameter screen, tap **F2** or directly tap the “RunSet” button to enter the battery running parameter screen.

The running parameters screen is used to set the running parameters, such as the power action when SOC discharge reaches 0 % or charge reaches 100 %, and the display mode of V-Soc curve during operation.

Figure 3-9-3

Running parameters interface



Running parameters interface as shown in Figure 3-9-3, you can perform the following operations:

- F4 / touch “Return”: back to battery parameters
- Menu key: switch modes
- Lock key: lock/unlock

Figure 3-9-4

SOC parameters interface



If Battery Type is set to Custom, F3 key or tap “Soc Set” button, enter the SOC setting interface;

The SOC parameter interface is used to set important SOC 0 % to 100 % nodes. All data must be in ascending order, for example, SOC 10 % node data ≥ SOC 0 % node data.

On the Soc parameter interface, you can perform the following operations:

F2 function key, Touch the “Generate” button, you can automatically calculate SOC 0 % to 100 % based on the three parameters of battery parameters “VolMax”, “VolStandard” and “VolMin” according to the algorithm.



Note

This algorithm is an evaluation algorithm summarized by nearly 10 kinds of battery models, and there are differences with the SOC value of the actual battery. If you want to accurately simulate the battery characteristics, please input SOC node data according to the battery manufacturer or paper data.

- F4 / touch “Return”: back to battery parameters
- Menu key: switch modes
- Lock key: lock/unlock

Battery Simulation Parameters

No.	Page	Item	Item Type	Description
1.	Battery parameters	Battery	Options	Fixed battery: Lithium manganate LMO, lithium cobaltate LCO, lithium iron phosphate LFO, ternary lithium NCM, Lithium Titanate LTO, lead-acid battery Pb, NiMH battery, NiCd battery and custom battery
		Battery Capacity	Numerical	Set the capacity of the simulated single battery in Ah
		Internal resistance (Res)	Numerical	Set the internal resistance of a single battery, unit Ω , the actual internal resistance of the final battery is also affected by the "series number" and "parallel number"
		VolMax	Numerical /Display	Simulate the upper voltage, standard voltage, and lower voltage of a single battery. If the battery type is fixed, this parameter is used for display only. You can modify it if it is customized. It is the input data automatically generated by the SOC.
		VolStandard		
		VolMin		
		Serial no.	Numerical	Set the number of series of the simulated battery
		Parallel no.	Numerical	Set the number of parallel connections of the simulated battery
		SOC initial	Numerical	Set the initial State of charge (SOC). SOC 0 % to 100 % Indicates the voltage range from the empty voltage to the full voltage.
Charge IMax	Numerical	Set the negative current limit to		

				simulate the maximum charging current of the battery pack. In practice, I _{max} should not be larger than the single section capacity * parallel number.
		Discharge I _{Max}	Numerical	Set the positive current limit to simulate the maximum discharge current of the battery pack. In practice, I _{max} should not be larger than the single section capacity * parallel number.
2.	Running parameters	SOC limit	Options	Stop/limit Simulate whether the action of the power supply when the battery discharge reaches SOC 0 % or when the charge reaches 100 % stops the power output or limits the current.
		Curve Shows	Options	Charge/discharge When the simulated battery is running, is the curve displayed a charging curve (SOC 0% to 100 % rise curve, as shown in Figure 3-9-6) or a discharge curve (SOC 100 % to 0 % decline curve, as shown in Figure 3-9-7)
3.	SOC parameters	0~100%	Numerical	SOC 0 % to 100 % Indicates the voltage range from the empty voltage to the full voltage. A total of 11 numerical points ranging from 0 % to 100 %, please refer to the battery manual or relevant paper data to fill in the battery open circuit voltage (OCV value)

Table 3-9-1 Battery simulation parameters list



Note

The resolution of the battery voltage parameter is 2 bits, for some high-voltage (500 V power supply) power supply set resolution is 1 bit, when the number

of series is small, due to the resolution problem, resulting in the lowest level of the battery can not be simulated. If you need to accurately simulate low-voltage battery conditions, choose the right power supply model.

Parameter setting limit: (When the parameter exceeds the limit value, a warning sign will flash in the upper right corner. If you touch the warning sign or start the operation, a prompt will be triggered, as shown in Figure 3-9-5.)

$V_{max} \geq$ Upper limit of the total battery voltage

$P_{max} \geq$ Upper limit of total battery power

Battery Max > Battery Standard > Battery Min

$(\text{Max battery vol} - \text{min battery vol}) \geq 0.4 \text{ V}$

Soc 0 % to 100 % requires ascending order

Figure 3-9-5

Battery parameters interface - limit prompt



Battery Simulation - Running

Press the **OnOff** key to start battery simulation, and the power supply enters the battery simulation running interface, as shown in the figure. According to "Curve shows" in the power supply running setting parameters, it can be divided into charging display mode and discharge display mode:

Figure 3-9-6

Battery parameters running interface - charging display mode

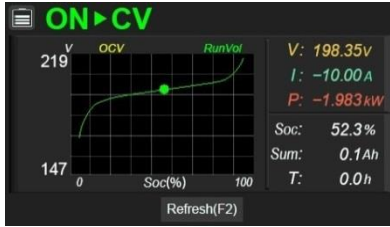

Figure 3-9-7

Battery parameters running interface - discharging display mode



On the battery simulation running interface, the V-Soc curve and real-time running point status are displayed on the left, the voltage, current, and power values are displayed on the upper right, and the current running Soc, Ah statistic Sum, and time statistic T are displayed on the lower right.

On the battery simulation run screen, you can perform the following operations:

- OnOff Function Key, Stops the battery simulation output of the power supply and returns to the battery parameter ready screen.
- F2 Function Key, Refresh the display curve.



Note

Individual input grid quality is poor, will interfere with the screen curve display, by refreshing the curve can be displayed normally.

- Lock Function Key, Enter or exit the locked state.

Figure 3-9-8

End of Battery Simulation

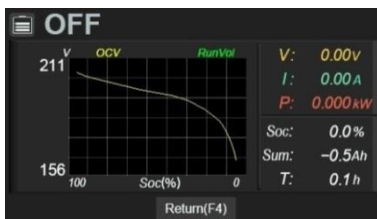

When the simulated battery discharge reaches SOC 0 % or the charge reaches 100 %, if the battery simulation running parameter is stopped, the battery simulation operation will be switched to the end interface (see Figure 3-9-8); if it is limited, the current will be kept at 0, waiting for the customer to manually stop the operation or switch the power mode (if the charge reaches 100 %, only the negative current will be 0. The positive discharge current is still the set value, so at this time, the power supply behind the switch to the load simulation can continue to discharge).

On Battery parameters run end interface you can perform the following operations:

- Lock Function Key, Enter or exit the locked state.
- F4 Function Key, Enter and exit to the battery simulation ready interface.
- Menu Function Key, Enter the menu to select other working modes.

Battery charge and discharge mode

The power supply has a battery charge and discharge working mode, and can be connected to the battery type load to charge and discharge the battery.

With a battery type load, there is an overshoot of no more than 1.05 set current at the start moment.

In charging mode, the power supply operates as illustrated in Figure 3-10-1. The battery is initially charged in constant current (CC) mode. Once the battery reaches a defined condition, it switches to constant voltage (CV) mode, and the charging current gradually decreases.

Charging ends when any of the following conditions is met:

The charging current drops below the set cut-off current (mandatory condition)

The charging time limit is reached (optional)

The charging capacity limit is reached (optional)

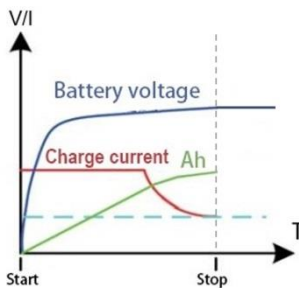

Figure 3-10-1
Battery charging status

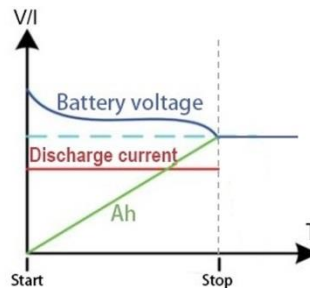

Figure 3-10-2
Battery discharge status

In discharging mode, as shown in Figure 3-10-2, the battery is discharged under constant current (CC) control. Discharging ends when any of the following conditions is met:

The battery voltage drops below the cut-off voltage (mandatory condition)

The discharge time limit is reached (optional)

The discharge capacity limit is reached (optional)



Note

In charge and discharge mode, the battery load must be connected, and corresponding prompts are displayed on the setting screen.

Battery Charge and Discharge Setting Screen

In the menu interface, click the number 2 button or directly touch the icon of battery charge and discharge to enter the battery charge and discharge setting interface, as shown in the picture. The lower right corner of the battery charge and discharge setting interface is the external connected battery voltage, and there are two pages for battery charge and discharge parameter state. The battery charging setting interface (as shown in Figure 3-10-3) and battery discharge setting interface (as shown in Figure 3-10-4) are respectively presented.

The battery charging/ discharging Settings screen allows you to perform the following operations:

- ON/OFF Key: Start or stop battery charging/discharging
- MENU Key: Return to the main menu to select other operating modes
- LOCK Key: Enter or exit the locked state

Figure 3-10-3
Battery charging setting interface



Figure 3-10-4
Battery discharge setting interface

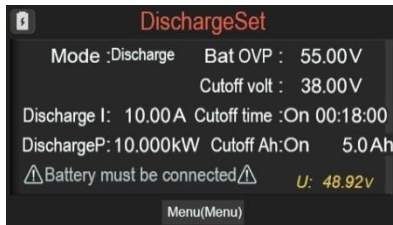

Description of battery charging and discharging parameters

No.	Page	Item	Item Type	Description
1	Charge setting	Mode	Options	Switch between charge mode/discharge mode
		Charge U	Numerical	Set the maximum battery charging voltage (unit V)
		Charge I	Numerical	Set the maximum battery charging current (unit A)
		Charge P	Numerical	Set the maximum battery charging power (unit: kW)
		Battery OVP	Numerical	Hardware protection to prevent overvoltage damage due to fault or mis-op
		Cutoff current	Numerical	Set the battery charging cutoff current, when the cutoff condition triggered the current is less than this value, the power supply automatically ends the charging
		Cutoff time	Numerical	(Optional) Set the battery charging cutoff time, which is valid when the value is set to on and non-0, and the power automatically ends charging when the cutoff condition is triggered first.
		Cutoff Ah	Numerical	(Optional) Set the battery charging cutoff capacity, which is valid when the value is set to on and non-0. When the cutoff condition triggers the capacity first, the power supply automatically ends the charging.
2	Discharge setting	Mode	Options	Switch between charge mode/discharge mode
		Charge I	Numerical	Set the maximum battery discharge current (unit: A)
		Charge P	Numerical	Set the maximum battery discharge power (unit: kW)
		Battery OVP	Numerical	Hardware protection to prevent overvoltage damage due to fault or mis-op
		Cutoff voltage	Numerical	Set the battery discharge cutoff voltage. When the first trigger voltage of the

			cutoff condition is less than this value, the power supply automatically ends charging.
	Cutoff time	Numerical	(Optional) Set the battery discharge cutoff time. This parameter is valid when it is set to ON or non-0. When it is valid, the power automatically ends charging when the cutoff condition is triggered first.
	Cutoff Ah	Numerical	(Optional) Set the battery discharge cutoff capacity. This parameter is valid when it is set to ON or non-0. When it is valid, the power automatically ends charging when the cutoff condition triggers the capacity first.

Table 3-10-1 Battery charging and discharging parameters list

Battery Charging and Discharging - Running

Battery charging and discharging interface Press **OnOff** button to start the battery charging and discharging operation, and the power supply enters the battery charging and discharging running interface, as shown in the figure. According to the power supply according to the working mode, it is divided into charging and discharging operation interface:

Figure 3-10-5

Battery charging running interface

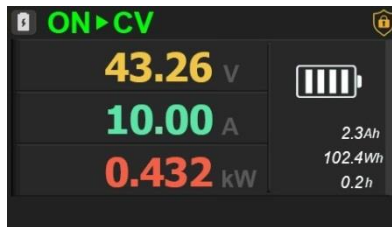

Figure 3-10-6

Battery discharging running interface



The left side of the screen displays real-time sampled values of voltage, current, and power.

The upper-right area shows an animated charging/ discharging status icon.

The lower-right area displays the accumulated values of:

- Ah (ampere-hours)
- Wh (watt-hours)
- T (time elapsed)

You can perform the following operations on the battery charge and discharge running screen:

OnOff function key, Stop the battery charging and discharging operation, return to the battery charging and discharging setting interface.

Lock Function Key, Enter or exit the lock state.

When the charge and discharge reach the cut-off condition, the power supply stops output and switches to the battery charge and discharge running end interface (see Figure 3-10-7 and 3-10-8).

Figure 3-10-7
Battery charge running end interface



Figure 3-10-8
Battery charge and discharge running end interface



You can perform the following operations on the battery charging and discharging running end screen:

- F4 function key, Return to the battery charging and discharging setting interface.
- Menu Function Key, Enter the menu to select other working modes.
- Lock Function Key, Enter or exit the lock state.

Load mode

There are a total of eight load operating modes available: CC, CV, CP, CR, CVCC, CVCR, CCCR, and AUTO.

In standby state, as shown in Figure 3-11-1, the user may tap or select the displayed operating mode (e.g., Auto), and switch between the eight available load modes:

Figure 3-11-1

Load Ready
Interface - AUTO
mode



Load mode introduction

(1) CC (Constant Current) Mode

The electronic load sinks a fixed current according to the preset CC value.

Commonly used with constant voltage sources or batteries, for evaluating their behavior under various current conditions.

(2) CV (Constant Voltage) Mode

The electronic load maintains a fixed voltage as set by the CV value.

Commonly used with constant current sources, such as chargers or EV charging stations, to evaluate their voltage behavior.

(3) CP (Constant Power) Mode

The load dynamically adjusts its current such that Power ($P = V \times I$) remains constant.

Suitable for simulating power consumption behavior of devices such as batteries or switching power supplies during discharge or dynamic loading tests.

(4) CR (Constant Resistance) Mode

The load acts as a resistive load based on the preset CR value.

As the input voltage changes, the load current adjusts linearly to maintain the resistance.

Ideal for testing voltage sources under varying resistive conditions.

(5) CVCC (Compound CV + CC) Mode

The load operates in CV mode first, using the preset voltage.

If the DUT output continues to rise such that the load current exceeds the preset CC limit, the load switches to CC mode.

Commonly used in battery discharge or EV charger tests.

(6) CVCR (Compound CV + CR) Mode

Initially operates in CV mode using the preset voltage.

If the DUT output rises and the equivalent load resistance exceeds the preset CR limit, the load switches to CR mode.

Suitable for simulating LED loads or testing LED power supplies.

(7) CCCR (Compound CC + CR) Mode

Starts with CR mode using the preset resistance.

If the DUT output current rises and exceeds the preset CC limit, the load switches to CC mode.

Commonly used in on-board charger (OBC) testing.

(8) AUTO Mode (CV + CR + CC + CP Hybrid)

The load initially operates in CV mode using the preset voltage.

If the DUT voltage continues to rise, the mode transitions to CR mode, then to CC mode, and eventually switches to CP mode in case of abnormal high voltage.

Ideal for simulating Li-ion battery chargers or devices requiring dynamic mode transitions.

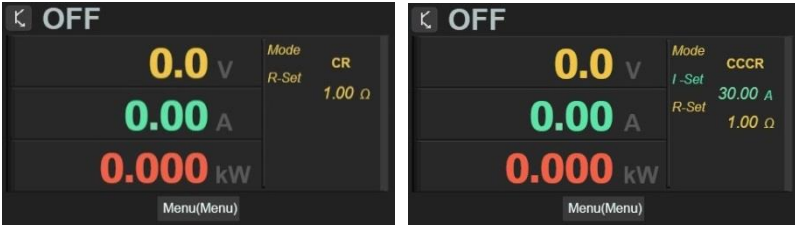

Figure 3-12-1 Examples of load standby: CR mode and CCCR mode

Load Mode – Standby State

Similar to the source mode, the load standby screen allows users to: Directly tap the Set area on the touchscreen to configure parameters. Use the direction keys to highlight items.

Use shortcut keys for quick access to settings.

In standby state, the following operations are available:

- V-set Function key selects CV setting (if present), click again to deselect.
- I-Set Function key to select CC Settings (if present), click again to deselect.
- P-Set Function key to select CP Settings (if present), click again to deselect.
- ← or → Function key toggles between Resistance Setting/ Current Setting/ Power Setting options.
- Esc key to deselect the item.

When the item is selected, the knob can be pressed down (after which it becomes the middle button of the knob) to switch the adjustment rate of the knob. The icon in the upper right corner shows the adjustment rate of the knob.

- OnOff Function key, Start the load mode.
- Menu Function key/ Tap the Menu button to enter the menu and select another working mode.

Load Mode - Operating State

Press the ON/OFF key while in standby to activate the load based on the set parameters.

If the startup is successful, the indicator above the ON/OFF key lights up, and the status bar displays real-time operating status.

While in the active load state, the following functions are available:

- V-set Function key selects CV setting (if present), click again to deselect.
- I-Set Function key to select CC Settings (if present), click again to deselect.
- P-Set Function key to select CP Settings (if present), click again to deselect.
- ← or → Function key toggles between Resistance Setting/ Current Setting/ Power Setting options.
- OnOff Function key, Stops the load operation and returns to standby.

Figure 3-11-3

Load Mode
Operating
Interface



Additional Notes on Load Mode

(1) Load Resistance Setting Range

- Minimum value: 0.01 Ω , with 0.01 Ω resolution.
- Maximum value depends on voltage rating and parallel unit count.
- For a single unit:
 - 1500 V model: up to 1500 Ω
 - 80 V model: up to 80 Ω
- For parallel systems:

Max resistance is inversely proportional to the number of units.

- Example:

Two 1500 V units in parallel → Max 750 Ω

Three 1500V units in parallel → Max 500 Ω

(2) Resistance accuracy

- Within 10–100% of voltage and current range: accuracy within $\pm 1\%$.
- Outside this range, accuracy may degrade, reaching errors up to $\pm 5\%$.

(3) Abnormal Resistance Range Operation

- Below 1% of rated voltage range, large current output may not be possible.
- Load current and power must not exceed the unit's maximum current and maximum power ratings.



Note
(Applicable to
Load/ Sink
Operation)

When the RBS is operated in Load Mode (or used as a Sink), compatibility issues may occur depending on the output characteristics of the connected power supply or DUT (Device Under Test). The following behaviors may be observed:

1. Minor Current Display Deviation

When the DUT outputs voltage to the RBS while the [ON/OFF] key has not yet been pressed, a small load current (below 1.3 A) may actually flow, even though the panel display shows 0 A.

This is a normal phenomenon caused by a minor conduction current at the input terminal.

2. Display Limitation for Low Current

In CC / CP / CR modes, when the load current is less than 1.3 A, the panel may still indicate 0 A, although a small current is present in reality.

This behavior is due to the display resolution limit and does not affect normal operation.

3. CV Mode Load Connection Issue

If the load cannot be established properly in CV mode, it is recommended to increase the current

limit setting of the DUT to ensure that the voltage can be properly built up and the load can be applied smoothly.

Parallel and Series power supplies

When the voltage or current of a single power supply can not meet the demand, it can meet the greater voltage and current demand through 2 series or up to 10 parallel (Only models RBS05K-100, RBS10K-100, and RBS15K-100 (100V output models) support series connection).

Parallel Connection

At most 10 power supplies of the same model can be connected in parallel. There are two interfaces on the rear panel of the chassis, respectively marked as "PARA OUT" and "PARA in ". Through these two interfaces, the "Master/Slave" mode is used to achieve parallel connection, as shown in the figure. Follow the steps below.

-
- | | |
|-------|--|
| Steps | <ol style="list-style-type: none">1. To set up the system, first select a host as the Master. The host user designates the Master, and on the parameter screen, the Master sets the "Online Set" option to Master and specifies the "Online Quantity" as the number of parallel machines. For each Slave, the "Online Set" option should be changed to Slave, and the "Online Quantity" should likewise be set to the number of parallel machines. |
|-------|--|



1. Change the "Online Set" option to "Slave". If no parallel cable is connected, the machine can operate independently. If the parallel cable is connected successfully, the machine will receive the parallel signal from the host and cannot operate on its own.
 2. When the Slave triggers an alarm, it will stop output and issue the alarm. After the alarm is cleared, the Slave cannot operate until the power supply is turned off and the alarm condition is resolved. Once resolved, the entire power supply must be restarted to allow the output to resume.
-

2. Turn off all power supplies, then connect the PARA OUT interface on the rear panel of the Master to the PARA IN interface of the first Slave (Slave 1) using a parallel signal cable.
3. Connect the PARA OUT interface of Slave 1 to the PARA IN interface of the next power supply (Slave 2) with a parallel signal cable. Repeat this step to continue the connection, supporting up to 10 power supplies in total.
4. Connect all output positive terminals of the power supplies together and connect them to the load.
5. Connect all output negative terminals of the power supplies together and connect them to the load.
6. Check all cable connections to ensure there is no short circuit between the positive and negative terminals.
7. Connect the SENSE lines. Each Slave's SENSE line should be connected directly to its own output positive and negative terminals. The Master can be connected in two ways:
 - With lead voltage drop compensation: connect the Master's SENSE wires directly to both ends of the load.
 - Without lead voltage drop compensation: connect the Master's SENSE wires directly to its own output positive and negative terminals.Use twisted pair wires for all SENSE connections and keep them as short as possible. When lead voltage drop compensation is enabled, the voltage displayed on the Slaves will be slightly higher than that of the Master.

8. Turn on all power supplies. When the connections and settings are correct, all Slaves will automatically enter the state shown in Figure 3-12-2. At this point, the Master can set the desired operating mode and parameters such as voltage and current to start the power output. After parallel connection, the system functions as a single power supply that can only be controlled from the Master. All Slave keys and communication functions become invalid (except the On/Off key, which can stop an individual Slave but will trigger an alarm).
9. To restore a single-machine setup, remove all output and parallel signal cables between the units, turn on the power supplies individually, and set "Online Set" to Single Machine.

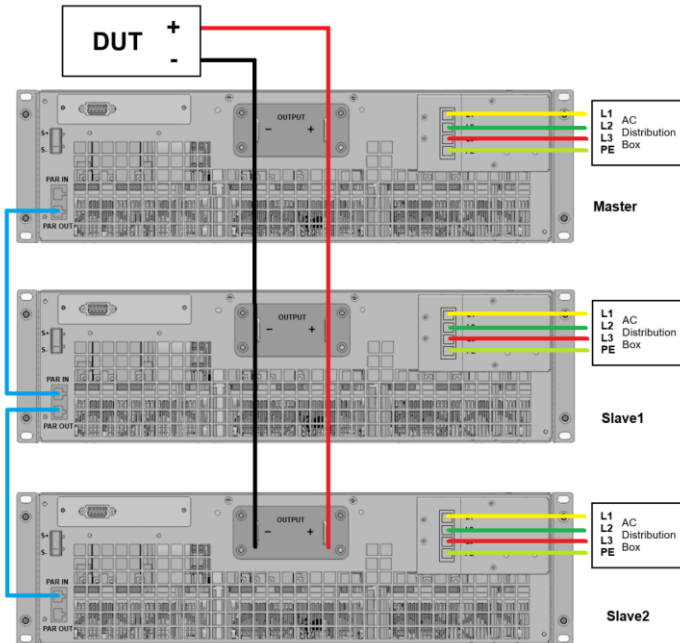
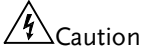
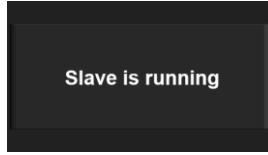

Figure 3-12-1 Parallel wiring

Figure 3-12-2

Parallel
Connection, Slave
Screen



Caution

If voltage upper limits differ across units, the system will use the lowest upper limit.

Set each Slave's voltage limit to maximum, and the Master's to the desired working voltage.

Series Connection

Higher output voltage is obtained by connecting two power supplies of the same model in series. Series operation connects the negative electrode of one power supply to the positive electrode of the other power supply.



Note

1. Only models RBS05K-100, RBS10K-100, and RBS15K-100 (100V output models) support series connection.
2. The negative voltage of all power supplies to the ground shall not exceed 300V.
3. The maximum current of two series is the same as that of a single set.
4. In series, lead voltage drop compensation function is not available.
5. It is necessary to use a continuation diode in parallel to the output of the power supply to prevent the current from flowing into the power supply in the shutdown state when one is on and started and the other is off. The schematic diagram is shown in Figure 3-12-2.

Figure 3-12-3

Schematic
diagram of series
wiring

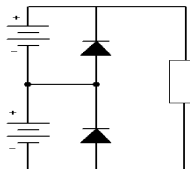

Shutdown

1. Press ON/OFF to stop output and enter standby.
2. Toggle the power switch on the front panel to “O” (off).
3. Wait until the LCD display turns completely off.
 - Some models may display a power-down screen; others may not.
 - A temporary module fault alarm may occur during shutdown
 - This is normal.
4. Finally, disconnect the AC input power cable.

INSPECTION AND MAINTENANCE

Guide	<ul style="list-style-type: none"> • Maintenance and Care • Troubleshooting • Storage and Transportation
Maintenance and Care.....	105
Scheduled Maintenance	105
Routine Maintenance	105
User repair	105
Maintenance and Care for Long-term Storage	105
Alarm code list.....	107
Storage and Transportation.....	108
Storage.....	108
Transportation	108
Package	108
Transportation.....	108

Maintenance and Care

Scheduled Maintenance

If the equipment is not used for a long time, it should be powered on once a month, and the power time is not less than 30 minutes.

Routine Maintenance

It is recommended to do at least one year of the following work

- (1) Regularly check whether the input and output wiring is firm to prevent overheating caused by electrical loosening.
- (2) Regularly check all warning signs on the instrument, and timely replace all warning signs that are not easy to see.
- (3) Visual inspection of all exposed parts.

For outdoor power supplies, we recommend:

- (4) Check rubber seals.

For mobile installed power supplies:

- (5) Check tires for wear and cracks.
 - (6) Check whether the air pressure is correct,
-



We recommend checking tire pressure frequently

User repair

It is forbidden to open the case of the instrument without authorization to prevent accidental electric shock; It is not allowed to change the wiring or parts of the instrument without authorization, if there is a change, the quality assurance commitment of the instrument will automatically fail. If the instrument is found to be altered without authorization, the company's technicians will restore the instrument and charge maintenance fees



Do not attempt to open the instrument without professional training, as this may cause personal injury or equipment damage.

Maintenance and Care for Long-term Storage

- (1) Long-term storage of the instrument pay attention to the storage environment, see chapter 2.2 for details.
- (2) Please simply clean the dust on the surface of the instrument before starting.
- (3) Prepare to check before starting the machine. For details, see section 2.1.
- (4) Observe the normal operation of the instrument after starting, if there is any abnormality or fault, please stop using immediately, unplug the power cord or disconnect the power from the distribution box, do not use before the product is repaired.

Alarm code list

Alarm code	Alarm content
0	No alarm
1	Hardware module failure
2	Hardware over-voltage protection (OVP)
3	Hardware over-temperature protection (OTP)
4	Output S terminal polarity reversed
5	User-defined over-voltage protection (OVP)
6	User-defined under-voltage protection (UVP)
7	User-defined over-current protection (OCP)
8	User-defined under-current protection (UCP)
9	Hardware module failure (during sequence operation)
10	Software over-voltage protection (S-OVP)

Storage and Transportation

Storage

Storage ambient temperature :-10 °C to 70 °C

Storage relative humidity: not more than 90 % (high humidity environment storage, it is recommended to run regularly 20 minutes to avoid water vapor condensation).



Caution

Dust protection should be taken during storage, and stacking any items on the instrument is prohibited.

Transportation

Package

Original packaging should be used when the instrument is repaired or transported. If the original packaging cannot be found, it must be packed according to the following requirements:

First use a plastic bag to seal the instrument;

Then place the equipment in a wooden box or multi-layer carton that can bear 50 kG weight;

Must be filled with shock-proof material, thickness of about 60 mm, the panel must be protected with thick plastic foam;

Properly seal the box and use a prominent sign to indicate “fragile products, please handle with care”.



Caution

When repairing, please be sure to pack all accessories such as power cord and test line together with the instrument, and please indicate the fault phenomenon.

Transportation

During transportation, severe turbulence, rough handling, rain and inversion should be avoided.

TROUBLESHOOTING

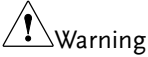

Warning

Only professionals can repair or maintain this unit, to avoid personnel injury or even death.

- OVP alarm
- Hardware Error Alarm
- No Display on Power-Up
- Overtemperature Alarm
- Sense Terminal Fault
- Significant Output Voltage Deviation

OVP alarm

Possible Cause	Solution
1. Actual output exceeds the preset OVP threshold	1. Reconfigure the OVP setting appropriately
2. Internal module failure	2. If the alarm cannot be cleared, contact the manufacturer or local agent

Hardware alarm

Possible Cause	Solution
1. Input voltage too low	1. Check if the single-phase/three-phase input wiring is correct and meets the required range
2. Internal module failure	2. If the alarm persists, contact the manufacturer or local agent

No Display on Power-Up

Possible Cause	Solution
1. Input power anomaly (e.g., phase loss, undervoltage)	1. Verify input wiring and measure voltage for proper single/three-phase supply
2. Ambient temperature too low	2. Leave the unit at room temperature for a period before restarting

Overtemperature Alarm

Possible Cause	Solution
1. Ambient temperature too high	1. Allow the unit to cool to room temperature before restarting
2. Internal module temperature too high	2. Reduce output power appropriately; if alarm persists, contact the manufacturer or agent

Sense Terminal Fault

Possible Cause	Solution
SENSE line connection error	Connect the SENSE lines properly to the output terminals or directly to the load; or disconnect the SENSE terminals if not used

Significant Output Voltage Deviation

Possible Cause	Solution
1. Output operating in current limit (CC) or constant power (CP) mode	1. Observe the front panel CV/CC/CP indicator lights
2. SENSE line connection error	2. Properly connect the SENSE lines to the output or load; or disconnect them if unused

For more information, contact your local dealer or GW Instek at www.gwinstek.com / marketing@goodwill.com.tw.

COMMUNICATION

INTERFACE

Guide	<ul style="list-style-type: none"> • Communication Interface Description • Communication protocol
Communication Interface Description	113
RS232 interface (Factory Installed Options)	113
RS485 interface (Factory Installed Options)	113
LAN communication interface (Factory Installed Options) ..	114
CAN interface (Factory Installed Options)	114
USB interface (Factory Installed Options)	115
USB Type B	115
RBS Communication Protocol	116
Handle protocol	116
Communication agreement	116
Communication frame format	117
List of Commands	118
Description of Communication Commands	122
1.2.5.C Control Command	122
1.2.5.Q Query command	125
1.2.5.S Set command	129
1.2.5.G Query of setting command	136
1.2.5.e Execution error	139
Modbus Communication Protocol (RTU and TCP)	141
Modbus communication agreement	141
Definition of Modbus communication register	145
Examples of Modbus Communication Commands	155
Examples of ModbusR TCP Communication Commands	157
CAN Communication Protocol	161
Instruction	161
Command Syntax of CAN	162
Command Example of CAN	169

Communication Interface Description

The device offers two types of interface cards. One is an all-in-one interface card, featuring RS232, RS485, CAN, LAN, and USB interfaces (however, due to the high level of integration, standard RS232 and RS485 cables cannot be used and require an adapter harness). The other is a single GPIB interface card.



Note

Only LAN and USB interfaces support hot plugging. Do not plug or unplug other interfaces when the power is on, otherwise it may cause damage to the interface hardware.

RS232 interface (Factory Installed Options)

Figure I-1-1

RS232 interface

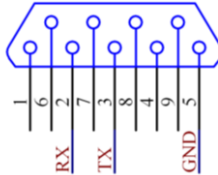

Figure I-1-1 shows the pin configuration for the RS-232 interface:

- Pin 2 → RX (Receive)
- Pin 3 → TX (Transmit)
- Pin 5 → GND

RS485 interface (Factory Installed Options)

Figure I-1-2

RS485 interface

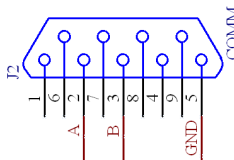

Figure I-1-2 shows the pin configuration for the RS-485 interface:

- Pin 2 → A
- Pin 3 → B
- Pin 5 → GND

A 120 Ω termination resistor is built-in across A and B inside the unit.

LAN communication interface (Factory Installed Options)

(1) Standard RJ-45 Ethernet port.

(2) Default factory settings:

- IP address: 192.168.0.253
- Subnet mask: 255.255.255.0
- Port: 5025

IP and port settings can be modified via the front panel. If unavailable, please contact technical support.

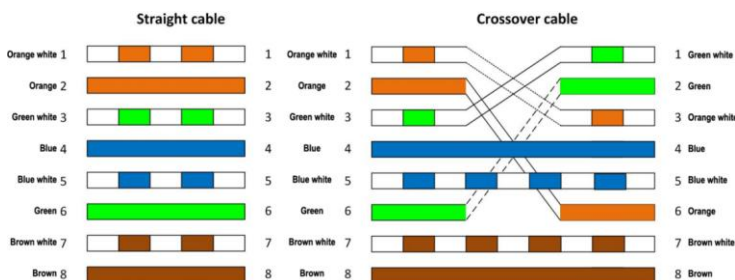

Figure I-1-3 Connection relationship between straight cable (left) and crossover cable (right)

(3) The normal computer or router network cable (Use CAT6 or higher) can work normally whether it is straight or cross; However, for older computers or routers, it may not be possible to identify the needs normally.

For older unidentifiable cases, where the power supply is equivalent to a computer, you need to connect to the network through a straight-through cable connected to the router. Or through the crossover cable directly connected with the computer, to achieve communication. Figure I-1-3 illustrates how to use a straight-through cable and crossover cable.

CAN interface (Factory Installed Options)

Figure I-1-4
CAN interface

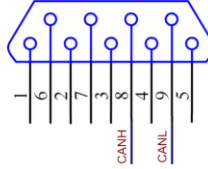

Figure I-1-4 shows the CAN pin configuration:

- Pin 8 → CANH
- Pin 9 → CANL

A custom-made CAN adapter cable is required for proper connection.

USB interface (Factory Installed Options)

USB Type B

When the power communication interface is set to USB, after the power is connected to the computer via a USB cable, the computer recognizes it as a USB-Enhanced SERIAL CH343(COMx) serial port device under the port (COM and LPT) classification, where COMx is a digital combination port number, for example, COM3 is the serial port number COM3. If it cannot be recognized, please search for "CH343 driver "online or ask the manufacturer for the driver. If it can be recognized, communication can be carried out through serial port-related tools (such as serial port debugging assistants, the manufacturer's upper computer configured according to RS232, and the programming platform accessed through serial port devices).

RBS Communication Protocol

Handle protocol

In the measurement and control network composed of master and slave (as shown in Figure I-2-1), a communication process is initiated by the download command of the master (hereinafter collectively referred to as “receiving command”) and ended by the response of the slave (hereinafter collectively referred to as “return command”).

Handshaking protocol adopts one-way handshaking protocol, that is, only the uploaded data from the slave machine contains information about whether the received host data is correct, and the host determines whether to resend the control command according to this information. After receiving the uploaded data from the slave, the host can judge whether the uploaded data is correct according to the error information it carries, and if it is wrong, it can resend the command to the slave.

On the other hand, after the master sends the command, it does not receive the return message within a certain period of time (for example, 100ms) (there will be no return command in case of check error and address error), and it can also resend the command to the slave.

Figure I-2-1
Handshake
Protocol

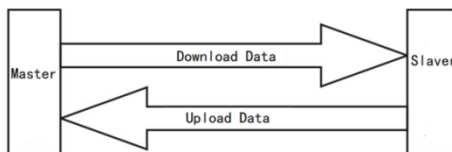

Communication agreement

- 1) The PC is the master by default, and the power supply is the slave. The master-slave response mode is adopted, and the slave is not allowed to send data to the master except for special and clear commands.
- 2)波特率: 9600, 19200, 38400; 默认值是 38400.
- 3) 地址范围: 1 ~ 250.

- 4) Data frame format: 1 start bit, 8 data bits and 1 stop bit, totally 10 bits.
- 5) The lower computer locks the keyboard after receiving the command of correct address and correct check.
- 6) Do not respond to communication commands in self-check and analog control state.



Note

When the PC communicates with the power supply, when there is large software running or firewall on the PC side, the communication response measured by the PC side will be lengthened. Therefore, when there is a time requirement for communication, please try to turn off the large software running or firewall.



Note

When using this machine to communicate with PC, you must ensure that the power address setting is consistent with the address in the communication command!

Communication frame format

Frame header	Address	Number of bytes	Command			Checksum	Frame end
			Command class	command word	command parameter		
0x3C	X	X	X	X	XXXXXX	X	0x3E

Table I-2-1 RBS Frame format (Hex)



Note

1. Each X represents a byte.
2. The bytes of command parameter is different based on the length of the command parameters.
 - a) Frame Header: 1 byte, fixed 0x3C, '<' ASCII code.
 - b) Address: 1 byte, address of the machine.
 - c) Total bytes: 1 bytes. Value: the sum of Frame Header + total bytes+ slave address + Command Class + Command Word+ Command Parameter + Checksum + End of Frame bytes, high bytes at the beginning, and low bytes following.

- d) Command: the length of bytes is different. See “Description of Command”.
- e) Checksum: 1 byte (hexadecimal), the check result of sent data. Adopt level check, that is the sum of bytes + slave address + command. Take the low bytes as the checksum.
- f) End of Format: 1 byte, fixed 0x3E, ‘>’ ASCII code.

List of Commands

The command class and command word are generally ASCII code values. For example, the hexadecimal code of the control class is 0x43, corresponding to the uppercase character “C”. 0x43(C) is used in the table. Generally speaking, the received command is uppercase character, and the returned command is corresponding lowercase character.

Command Class	Command(Sent)			Function	Command(Receive)		
	Type	Word	Parameter bytes		Type	Word	Parameter bytes
Control	0x43(C)	0x50(P)	0	CP. Output Off	0x63(c)	0x70(p)	0
		0x52(R)	0	CR. Output On		0x72(r)	0
		0x41(A)	0	CA. Exit Alarm		0x61(a)	0
		0x53(S)	2	CS. Set work mode		0x73(s)	0
		0x4E(N)	10	CN. Source Control		0x6E(n)	0
		0x4C(L)	2	CL. List Control		0x6C(l)	0
		0x56(V)	13	CV. PV SAS Control		0x76(v)	0
Query	0x51(Q)	0x4F(O)	0	QO. Query the output measurement values	0x71(q)	0x6F(o)	10
		0x53(S)	0	QS. Query the instrument status		0x73(s)	20
		0x56(V)	0	QV. Query the PV operating		0x76(v)	15

				parameters			
		0x52(R)	0	QR. Query the power Settings range		0x72(r)	22
Set	0x53(S)	0x55(U)	3	SU. Set source voltage	0x73(s)	0x75(u)	0
		0x49(I)	3	SI. Set source current		0x69(i)	0
		0x50(P)	3	SP. Set source power		0x70(p)	0
		0x4E(N)	9	SN. Set source parameters		0x6E(n)	0
		0x54(T)	15	ST. Set source bidirectional parameters		0x74(t)	0
		0x4C(L)	22	SL. Set list step parameters		0x6C(l)	0
		0x56(V)	12	SV. Set SAS parameters		0x76(v)	0
		0x45(E)	9	SE. Set EN50530 parameters		0x65(e)	0
		0x44(D)	13	SD. Set Sandia parameters		0x64(d)	0
		0x47(G)	5	SG. Set PV Setting		0x67(g)	0
		0x42(B)	23	SB.Set battery simulation parameters		0x62(b)	0
		0x4F(O)	22	SO.Set battery simulation SOC parameters		0x6F(o)	0
		0x52(R)	6	SR.Set battery simulation SOC parameters through the battery voltage range		0x72(r)	0

		0x43(C)	31	SC. Set battery charge & discharge parameters		0x63(c)	0
		0x41(A)	9	SN. Set load parameters		0x61(a)	0
		0x53(S)	3	SS. Set hardware OVP		0x73(s)	0
		0x5A(Z)	2	SZ. Set soft rise		0x7A(Z)	0
		0x59(Y)	48	SY. Set system parameters		0x79(y)	0
Query of Setting	0x47 (G)	0x4E(N)	0	GN. Query setting source parameters	0x67(g)	0x6E(n)	9
		0x54(T)	0	GT. Query setting source bidirectional parameters		0x74(t)	15
		0x4C(L)	2	GL. Query setting list parameters		0x6C(l)	22
		0x56(V)	0	GV. Query setting SAS parameters		0x76(v)	12
		0x45(E)	0	GE. Query setting EN50530 parameters		0x65(e)	9
		0x44(D)	0	GD. Query setting Sandia parameters		0x64(d)	13
		0x47(G)	0	GG. Query setting PV Setting		0x67(g)	5
		0x42(B)	0	GB. Query setting battery simulation parameters		0x62(b)	23
		0x4F(O)	0	GO. Query setting battery simulation SOC parameters		0x6F(o)	22
		0x43(C)	0	GC. Query setting charge & discharge parameters		0x62(b)	31
		0x41(A)	0	GN. Query setting load parameters		0x61(a)	9

	0x53(S)	0	GS. Query setting hardware OVP		0x73(s)	3
	0x5A(Z)	0	GZ. Query setting soft rise		0x7A(Z)	2
	0x59(Y)	0	GY. Query setting system parameters		0x79(y)	48
Execution error			e1.Command type error	0x65(e)	0x74(t)	4
			e2.Command word error		0x77(w)	4
			e3.Execution error		0x73(s)	4
			e4.Parameter error		0x72(r)	4
			e5.Length error		0x6C(l)	4

Table I-2-2 RBS list of commands



Note

1. The maximum resolution of voltage is 0.01V, the maximum resolution of 550V voltage and above will be reduced to 0.1V; The maximum resolution of current is 0.01A, and the maximum resolution of 1000A current and above models will be changed to 0.1A; The highest resolution of power is 0.001kW, and the highest resolution of 100kW power and above models will be changed to 0.01kW; The larger voltage, current and power resolution is based on the analogy of 5-bit effective data, and the actual unit value can be obtained through the “QR. Query power Settings Range” communication command. The examples in the detailed explanation of communication commands are all in units of 0.01V, 0.01A, and 0.001kW.
2. Photovoltaic related content is only valid when the photovoltaic function is enabled.
3. After the photovoltaic startup and online adjustment command is executed, there will be tens of ms unable to respond to the communication command due to the need to calculate the photovoltaic curve.

Description of Communication Commands

In the command examples, the default address is 1.

For example, the return value of the return command is successfully executed without special instructions.

Each X represents a number of bytes.

Rec. Indicates an Example for receive commands.

Rtn. Indicates an Example for return commands.

I.2.5.C Control Command

I.2.5.CP Output Off, Only the running state can be executed

Rec.:3C 01 07 **43 50** 9B 3E (7bytes)

Rtn.:3C 01 07 **63 70** DB 3E (7bytes)

I.2.5.CR Output On, Only the ready state can be executed

Rec.:3C 01 07 **43 52** 9D 3E (7bytes)

Rtn.:3C 01 07 **63 72** DD 3E (7bytes)

I.2.5.CA Exit Alarm, Only the alarm state can be executed

Rec.:3C 01 07 **43 41** 8C 3E (7bytes)

Rtn.:3C 01 07 **63 61** CC 3E (7bytes)

I.2.5.CS Set work mode, only the ready state can be executed

Receive command format:3C 01 09 **43 53** X*2 X 3E (9bytes)
(Parameters are defined in I.2.5.CS)

Rec.:3C 01 09 **43 53** 4E 00 EE 3E (set source mode)

Rec.:3C 01 09 **43 53** 4C 00 EC 3E (set list mode and set the number of sequence to 0)

Rec.:3C 01 09 **43 53** 56 56 4C 3E (set PV SAS mode)

Rec.:3C 01 09 **43 53** 56 45 3B 3E (set PV EN50530 mode)

Rec.:3C 01 09 **43 53** 56 44 3A 3E (set PV Sandia mode)

Rec.:3C 01 09 **43 53** 42 00 E2 3E (set Battery simulation mode)

Rec.:3C 01 09 43 53 43 00 E3 3E (set charge & discharge mode)

Rec.:3C 01 09 43 53 43 26 3E (set charge mode)

Rec.:3C 01 09 43 53 43 44 27 3E (set discharge mode)

Rec.:3C 01 09 43 53 41 00 E1 3E (set load mode)

Rtn.:3C 01 07 **63 73** DE 3E (7bytes)

No.	0	1	Total
Bytes	1	1	2
Position*1	5	6	
Explain	0x4E(N) Source	0x54(T) Bidirectional parameter mode Other parameters are source mode	
	0x4C(L) List	Number of sequence*3	
	0x56(V) PV	0x00:SAS (Compatible with older versions) V:SAS E:EN50530 D:Sandia	
	0x42(B)Battery simulation	Invalid*2	
	0x43(C)Charge & Discharge	0x43(C)battery charge mode 0x44(D)battery discharge mode other: charge or discharge by mode setting	
	0x41(A) Load	Invalid	

Table I.2.5.CS Set work mode parameters



Note

- *1 Position refers to the bytes position of the entire command (subscript starting from 0)
- *2 Invalid indicates that the bytes data has no actual meaning. You can fill in 0 when setting the bytes. The returned data is usually 0.
- *3 Serial number 00-49 indicates a valid serial number. 0xFF indicates that the serial number of the current power supply remains unchanged.

I.2.5.CN Source Control, only ready state (and switch to source mode) or source mode can be executed

Receive command format:3C 01 11 **43 4E** X*10 X 3E (17bytes)
(Parameters are defined in I.2.5.CN)

Rec.:3C 01 11 **43 4E** 00 00 00 00 00 00 00 00 00 00 00 00 A3 3E (source output off)

Rec.:3C 01 11 **43 4E** 01 00 1F 40 00 27 10 00 05 DC 1B 3E (source output on with 80V, 100A, 1.5kw)

Rtn.:3C 01 07 **63 6E** D9 3E (7bytes)

No.	0	1	2	3	Total
Bytes	1	3	3	3	10
Position	5	6-8	9-11	12-14	
Explain	0 output off	Invalid	Invalid	Invalid	
	1 output on/Online adjust	V-set	I-set	P-set	

Table I.2.5.CN source control parameters

I.2.5.CL List Control, only ready state (and switch to list mode) or list mode can be executed

Receive command format:3C 01 09 **43 4C** X*2 X 3E (9bytes)

(Parameters are defined in I.2.5.CL)

Rec.:3C 01 09 **43 4C** 00 00 99 3E (list output off)

Rec.:3C 01 09 **43 4C** 01 00 9A 3E (List output on with sequence 0)

Rtn.:3C 01 07 **63 6C** D7 3E (7bytes)

No.	0	1	Total
Bytes	1	1	2
Position	5	6	
Explain	0x00 output off	Invalid	
	0x01 output on	No. of sequence	
	0x02 output on with one step	No. of sequence	
	0x10 Pause	Invalid	
	0x11Continue	Invalid	

Table I.2.5.CL List control parameters

I.2.5.CV PV SAS Control, only ready state (and switch to PV mode) or PV mode can be executed

Receive command format:3C 01 14 **43 56** X*13 X 3E (20bytes)

(Parameters are defined in I.2.5.CV)

Rec.:3C 01 14 **43 56** 00 00 00 00 00 00 00 00 00 00 00 00 00 AE 3E (PV output off)

Rec.:3C 01 14 **43 56** 01 00 AF C8 00 9C 40 00 0D AC 00 0B B8 7E 3E (PV output on with 450V, 400V, 35A, 30A)

Rtn.:3C 01 07 **63 76** E1 3E (7bytes)

No.	0	1	2	3	4	Total
Bytes	1	3	3	3	3	13
Position	5	6-8	9-11	12-14	15-17	
Explain	0 output off	Invalid	Invalid	Invalid	Invalid	
	1 output on/Online adjust	Voc	Vmp	Isc	Imp	

Table I.2.5.CV PV SAS control parameters



Note

If the parameter setting error return position is 5, it indicates that the new parameter does not meet the requirements on page 57.

I.2.5.Q Query command

Query classes can be executed normally in the communication state

I.2.5.QO Query the output measurement values

Rec.:3C 01 07 **51 4F** A8 3E (7bytes)

Return command format:3C 01 11 **71 6F** X*10 X 3E (17bytes)

(Parameters are defined in I.2.5.QO)

Rtn.:3C 01 11 **71 6F** 02 00 1F 40 00 27 10 00 05 DC 6B 3E (CV, 80V, 100A, 1.5kW)

No.	0	1	2	3	Total
Bytes	1	3	3	3	10
Position	5	6-8	9-11	12-14	
Explain	Output state *1	Output voltage	Output currentNote2	Output power*2	

Table I.2.5.QO Return parameters of query the output measurement command



Note

*1 0 ready,1 begin start,2 CV,3 CC,4 CP,5 PV mode,6 CR.

*2 When the current and power are negative, the highest bit is 1, and the higher 8 bits need to be replaced by 1 when converting to a 32-bit value.

I.2.5.QS Query the instrument status

Rec.:3C 01 07 **51 53** AC 3E (7bytes)

Return command format:3C 01 1B **71 73** X*20 X 3E (27bytes)

(Parameters are defined in I.2.5.QS)

Rtn.:3C 01 1B **71 73** 6E 72 05 00 00 00 00 00 00 02 00 1F 40 00 27 10
 00 05 DC 5E 3E (source output on, 05 alarm tip, CV, 80V, 100A,
 1.5kW)

Rtn.:3C 01 1B **71 73** 6C 72 00 02 00 00 02 00 00 1A 02 00 13 88 00 42 68
 00 13 88 DE 3E (list output on,Seq2 Step0,Loop remaining 2 times,
 remaining time 2.6s, CV, 50V, 170A, 5kW)

Rtn.:3C 01 1B **71 73** 76 77 76 00 00 00 00 00 00 00 00 00 00 00 00 00 00
 00 00 00 63 3E (PV SAS ready)

No.	0	1	2	3-6	Total
Bytes	1	1	8	10	20
Position	5	6	7-14	15,16-18, 19-21, 22-24	
Explain	0x6E(n) Source mode		List ready:7bytes list current sequence PV ready: 7bytes PV mode	Output measured values, the contents of the table I.2.5.QO	
	0x74(t) Source bidirectional parameter mode	0x77(w) Ready 0x72(r) Running	0x76(v)-SAS, 0x65(e)-EN50530, 0x64(d)-Sandia 0x00-PV setting Ready state and other: Invalid		
	0x6C(l) List mode	0x70(p) List pause	Source running: 7bytes alarm tip, 8-9bytes remaining soft rise time		
	0x76(v) PV mode	0x65(e) Battery simulation running end/Charge & discharge running end	(unit:0.1s), other bytes: invalid PV running: 7bytes alarm tip, 8-9bytes remaining soft rise time		
	0x61(a) Alarm		(unit:0.1s), 10-11 bytes is Mpp instantaneous efficiency (unit 0.1%), other bytes: invalid		
	0x62(b) Battery simulation mode	0x00 Alarm and other	List running: 7bytes alarm tip, 8bytes running seq., 9bytes running step		
	0x63(c) Battery charge				

0x64(d) Battery discharge			No. , 10-11bytes remaining loop count, 12-14bytes remaining step time, unit:0.1s		
0x66(f) Load			Battery simulation running/ running end:		
0x6F(o) Other			7bytes alarm tip, 8-9byte Soc now (unit0.1%), 10-12byte total Ah (unit0.1Ah) (Note that negative numbers are complemented by FF), 13-14byte total time (unit0.1h)		
			Battery charge & discharge running/ running end: 7bytes alarm tip, 8-9 byte total Ah (unit 0.1Ah), 10-12 byte total Wh (unit 0.1Wh) 13-14byte total time (unit 0.1h)		
			Load running: 7bytes alarm tip, other bytes: invalid		
			Alarm: 7bytes Alarm code, 8-10bytes time of alarm occurrence		

Table I.2.5.QS return parameters of query the instrument status command

I.2.5.QV Query the PV operating parameters, only the PV running state can be executed

Rec.:3C 01 07 **51 56** AF 3E (7bytes)

Return command format:3C 01 16 **71 76** X*15 X 3E (22bytes)

(Parameters are defined in I.2.5.QV)

Rtn.:3C 01 16 71 76 00 AF C8 00 0D AC 00 94 24 00 0C CD 00 30 8B
 7A 3E (Voc450.00V, Isc35.00A, Vmp379.24V, Imp32.77A,
 Pmp12.427kW)

No.	0	1	2	3	4	Total
Bytes	3	3	3	3	3	15
Position	5-7	8-10	11-13	14-16	17-19	
Explain	Voc	Isc	Vmp	Imp	Pmp	

Table I.2.5.QV Return parameters of query the PV operating command

I.2.5.QR Query the power Settings range

Rec.:3C 01 07 **51 52** AB 3E (7bytes)

Return command format:3C 01 1C **71 72** X*22 X 3E (29bytes)

(Parameters are defined in I.2.5.QR)

Rtn.:3C 01 1D **71 72** 02 00 1F 40 00 00 00 01 00 3B C4 00 00 00 03 00 AF
 C8 00 00 00 19 F5 3E (0.00V-80.00V, 0.00A-510.00A,
 0.000kW-15.000kW, List function on, parallel count is 3)

No.	0	1	2	3	4	5
Bytes	1	3	3	1	3	3
Position	5	6-8	9-11	12	13-15	16-18
Explain	Voltage			Current		
	Decimal separator offset* ¹	Maximum	Minimum	Decimal separator offset	Maximum	Minimum

No.	6	7	8	9	Total
Bytes	1	3	3	1	22
Position	19	20-22	23-25	26	
Explain	Power			Function/ Parallel count	
	Decimal separator offset	Maximum	Minimum	* ²	

Table I.2.5.QR Return parameters of query the power Settings range command



*¹ The offset position of the unit decimal separator, taking voltage as an example, 0 indicates that the unit is 1 V, 1 indicates that the unit is 0.1 V, and 2

indicates that the unit is 0.01V.

*²0bit indicates whether there is a sequence function,.1bit indicates whether there is a photovoltaic function,.3-7bit indicates parallel count.

I.2.5.S Set command

I.2.5.SU Set source voltage, only ready state (and switch to source mode) or source mode can be executed

Receive command format:3C 01 0A **53 55** X*3 X 3E (10bytes) (3bytes voltage parameter)

Rec.:3C 01 0A **53 55** 00 13 88 4E 3E (set 50V)

Rtn.:3C 01 07 **73 75** F0 3E (7bytes)

I.2.5.SI Set source current, only ready state (and switch to source mode) or source mode can be executed

Receive command format:3C 01 0A **53 49** X*3 X 3E (10bytes) (3bytes current parameter)

Rec.:3C 01 0A **53 49** 00 17 70 2E 3E (set 60A)

Rtn.:3C 01 07 **73 69** E4 3E (7bytes)

I.2.5.SP Set source power, only ready state (and switch to source mode) or source mode can be executed

Receive command format:3C 01 0A **53 50** X*3 X 3E (10bytes) (3bytes power parameter)

Rec.:3C 01 0A **53 50** 00 07 08 BD 3E (set 1.8kW)

Rtn.:3C 01 07 **73 70** EB 3E (7bytes)

I.2.5.SN Set source parameters, only ready state (and switch to source mode) or source mode can be executed

Receive command format:3C 01 10 **53 4E** X*9 X 3E(16bytes)(Parameters are defined in table I.2.5.SN)

Rec.:3C 01 10 **53 4E** 00 15 7C 00 12 C0 00 09 C4 E2 3E (set 55V, 48A, 2.5kW)

Rtn.:3C 01 07 **73 6E** E9 3E (7bytes)

No.	0	1	2	Total
Bytes	3	3	3	9
Position	5-7	8-10	11-13	
Explain	Set voltage	Set current	Set power	

Table I.2.5.SN Set/Query source parameter

I.2.5.ST Set source bidirectional parameters, Only ready state (and switch to source bidirectional parameter mode) or source bidirectional parameter mode can be executed

Receive command format:3C 01 16 **53 54** X*15 X 3E(22bytes)(Parameters are defined in table I.2.5.ST)

Rec.:3C 01 16 **53 54** 00 15 7C 00 12 C0 00 09 C4 00 0B B8 00 07 D0 88
3E(set 55V,+48A,+2.5kW , -30A , -2kw)

Rtn.:3C 01 07 **73 74** EF 3E(7bytes)

No.	0	1	2	1	2	Total
Bytes	3	3	3	3	3	15
Position	5-7	8-10	11-13	14-16	17-19	
Explain	Set voltage	Set positive current	Set positive power	Set negative current	Set negative power	

I.2.5.ST Set/Query source bidirectional parameter

I.2.5.SL Set list step parameters, only ready state (and switch to list mode)

Receive command format:3C 01 1D **53 4C** X*22 X 3E (29bytes)
(Parameters are defined in Table I.2.5.SL)

Rec.:3C 01 1D 53 4C 02 00 00 00 0B B8 00 1B 58 00 0F A0 00 01 75 30
01 00 00 00 00 00 4B 3E (30V, 70A, 4kW, 1min30sec, no loop, next step)

Rtn.:3C 01 07 **73 6C** E7 3E (7bytes)

No.	0	1	2	3	4	5
Bytes	1	1	1	3	3	3
Position	5	6	7	8-10	11-13	14-16
Explain	Sequence 0-49	Step 0-19	Mode: 0 UIP	voltage	current	power
			1 U ramp	voltage begin	voltage end	current
			2 I ramp	current begin	current end	voltage

No.	6	7	8	9
Bytes	1	1	2	1
Position	17	18	19-20	21
Explain	Hour unit: h range:0-99h	Minute unit: m range:0-59m	Second unit: 0.001s range:0.1~59.999s	Enable: 0 Disable, 1 Enable, 2 Run & Pause

No.	10	11	12	13	Total
Bytes	1	2	1	1	22
Position	22	23-24	25	26	
Explain	Loop set: 0 normal 1 loop begin 2 Loop end	Loop count range: 0-9999	Operation: 0 next 1 stop 2 jump seq	jump seq range: 0-49	

Table I.2.5.SL Set/Query list parameter

I.2.5.SV Set SAS parameters, only ready state (and switch to PV SAS mode) or PV SAS mode can be executed.

Receive command format:3C 01 13 **53 56** X*12 X 3E (19bytes)
(Parameters are defined in Table I.2.5.SV)

Rec.:3C 01 13 **53 56** 00 19 64 00 17 70 00 07 D0 00 05 DC 79 3E
(Voc65.00V, Vmp60.00V, Isc20.00A, Imp15.00A)

Rtn.:3C 01 07 **73 76** F1 3E(7bytes)

No.	0	1	2	3	Total
Bytes	3	3	3	3	12
Position	5-7	8-10	11-13	14-16	
Explain	Set Voc	Set Vmp	Set Isc	Set Imp	

Table I.2.5.SV Set/Query PV SAS parameter



Note

When the parameter error return location is 4, the new parameters of the set are inconsistent with the requirement on page 57.

I.2.5.SE Set EN50530 parameters, only ready state (and switch to PV EN50530 mode) or PV EN50530 mode can be executed

Receive command format:3C 01 10 **53 45** X*9 X 3E (16bytes) (Parameters are defined in Table I.2.5.SE)

Rec.:3C 01 10 53 45 03 E8 00 75 30 00 05 DC 00 1A 3E (Irr1000W/m², Vmp300.00V, Pmp1.500kW, cSi)

Rtn.:3C 01 07 **73 65** E0 3E (7bytes)

No.	0	1	2	3	Total
Bytes	2	3	3	1	9
Position	5-6	7-9	10-12	13	
Explain	Set Irr	Set Vmp	Set Pmp	Set FF: 0-cSi;1-TF	

Table I.2.5.SE Set/Query PV EN50530 parameter



Note

When the parameter error return location is 4, the new parameters of the set are inconsistent with the requirement on page.

I.2.5.SD Set Sandia parameters, only ready state (and switch to PV Sandia mode) or PV Sandia mode can be executed

Receive command format:3C 01 14 53 44 X*13 X 3E (20bytes)

(Parameters are defined in Table I.2.5.SD)

Rec.:3C 01 14 53 44 03 E8 03 E8 19 19 00 75 30 00 05 DC 00 3A 3E
(Irr1000W/m², IrrREF1000W/m², TC25°C, TREF25°C, Vmp300.00V,
Pmp1.500kW, TF)

Rtn.:3C 01 07 73 64 DF 3E (7bytes)

No.	0	1	2	3	4	5	6	Total
Bytes	2	2	1	1	3	3	1	13
Position	5-6	7-8	9	10	11-13	14-16	17	
Explain	Set Irr	Set IrrREF	Set TC	Set TREF	Set Vmp	Set Pmp	Set FF 0-TF;1-SCMC;2-HEC	

Table I.2.5.SD Set/Query PV Sandia parameter



Note

When the parameter error return location is 7, the new parameters of the set are inconsistent with the requirement of 3.7.1.

I.2.5.SG Set PV Setting, Only the ready state can be executed

Receive command format:3C 01 0C 53 47 X*5 X 3E (12bytes) (Parameters are defined in Table I.2.5.SG)

Rec.:3C 01 0C 53 47 01 03 E8 02 05 9A 3E (CC, Filter 1000Hz, Speed 2, Margin 5%)

Rtn.:3C 01 07 73 67 E2 3E (7bytes)

No.	0	1	2	3	Total
Bytes	1	2	1	1	5
Position	5	6-7	8	9	
Explain	Search Model 0-CV;1-CC	Filter	Speed	Margin	

Table I.2.5.SG Set/Query PV setting parameter

I.2.5.SB Set battery simulation parameters, Only the ready state can be executed

Receive command format:3C 01 1E 53 42 X*23 X 3E (30bytes)

(Parameters are defined in Table I.2.5.SB)

Rec.:3C 01 1E **53 42** 00 00 64 00 00 00 00 00 00 00 00 0A 00 0A 01 F4
 00 64 00 64 01 01 EB 3E(Lithium manganate LMO, 10Ah, 0Ω, 10 Serial
 10 parallel, SOC initial 50%, I_{max} 1A, SOC limit stop, charge curve
 display)

Rtn.:3C 01 07 **73 62** DD 3E (7bytes)

No.	0	1	2	3	4
Bytes	1	2	2	2	2
Position	5	6-7	8-9	10-11	12-13
Explain	Battery type* ¹	Battery capacity unit 0.1Ah	Internal resistance unit 0.001Ω	Battery upper voltage unit 0.01V	Battery standard voltage unit 0.01V

No.	5	6	7	8	9
Bytes	2	2	2	2	2
Position	14-15	16-17	18-19	20-21	22-23
Explain	Battery lower voltage unit 0.01V	Serial no.	Parallel no.	Soc initial unit 0.1%	Charge I _{max}

No.	10	11	12	Total
Bytes	2	1	1	23
Position	24-25	26	27	
Explain	Discharge I _{max}	SOC reach limit 0Limit 1stop	Curve Shows 0Discharge 1Charge	

Table I.2.5.SB Set/Query battery simulation parameter



Note

*¹ 0 Lithium manganate LMO, 1 lithium cobaltate LCO, 2 lithium iron phosphate LFO, 3 ternary lithium NCM, 4 Lithium Titanate LTO, 5 lead-acid battery Pb, 6 NiMH battery, 7 NiCd battery, 8 custom battery

*² When the parameter error return location is 13, the new parameters of the set are inconsistent with the requirement on page 82.

I.2.5.SO Set battery simulation SOC parameters, Only the ready state can be executed

Receive command format:3C 01 1D **53 4F** X*22 X 3E (29bytes) (The specific parameter is 2 bytes 1 group, the first group represents SOC0%,

the first group represents SOC10%, and so on, the unit is 0.01V, and the value is required to be in ascending order)

Rec.:3C 01 1D **53 4F** 01 3B 01 66 01 6E 01 72 01 75 01 78 01 7B 01 7E 01 81 01 87 01 A1 DB 3E (An ascending array)
 Rtn.:3C 01 07 **73 6F** EA 3E (7bytes)



Note

If the error value is 11, the new parameter does not meet battery Soc ascending requirements.

I.2.5.SR Set battery simulation SOC parameters through the battery voltage range, Only the ready state can be executed

Receive command format:3C 01 0D **53 52** X*6 X 3E(13bytes)(Parameters are defined in Table I.2.5.SR)

Rec.:3C 01 0D **53 52** 01 F4 01 90 01 2C 66 3E (5V, 4V, 3V)
 Rtn.:3C 01 07 **73 72** ED 3E (7bytes)

No.	0	1	2	Total
Bytes	2	2	2	6
Position	5-6	7-8	9-10	
Explain	Battery upper voltage unit 0.01V	Battery standard voltage unit 0.01V	Battery lower voltage unit 0.01V	

Table I.2.5.SR Set battery simulation SOC parameters through the battery voltage range



Note

When the parameter error return location is 3, the new parameters of the set are inconsistent with the requirement of 3.9.2.

I.2.5.SC Set battery charge and discharge parameter, Only the ready state can be executed

Receive command format: 3C 01 26 **53 43** X*5 X 3E (38bytes) (Parameters are defined in Table I.2.5.SC)

Rec.: 3C 01 26 **53 43** 01 15 7C 14 00 03 E8 02 58 00 0A 01 00 0C 00 01 00 64 03 E8 27 10 0E D8 01 00 12 00 01 00 32 72 3E
 Rtn.:3C 01 07 **73 63** DE 3E (7bytes)

No.	0	1	2	3	4	5
Bytes	1	2	2	2	2	2
Position	5	6-7	8-9	10-11	12-13	14-15
Explain	Mode	Battery OVP	Charge voltage	Charge current	Charge power	Charge cutoff current

No.	6-9	10-11	12
Bytes	4	3	2
Position	16-19	20-22	23-24
Explain	Charge cutoff time:1byte: 0 off 1 on; Each hour, minute and second is 1 byte	Charge cutoff Ah: 1byte: 0 off 1 on; 2byte Ah unit 0.1Ah	Discharge current

No.	13	14	15-18	19-20	Total
Bytes	2	2	4	3	31
Position	25-26	27-28	29-32	33-34	
Explain	Discharge power	Discharge cutoff voltage	Discharge cutoff time: 1byte: 0 off 1 on; Each hour, minute and second is 1 byte	Discharge cutoff Ah: 1byte: 0 off 1 on; 2byte Ah unit 0.1Ah	

Table I.2.5.SC Set/Query battery charge and discharge parameter

I.2.5.SA Set load parameters, only ready state (and switch to load mode) or load mode can be executed

Receive command format:3C 01 10 **53 41** X*9 X 3E (16bytes) (Parameters are defined in table I.2.5.SA)

Rec.:3C 01 10 **53 41** 00 00 64 00 07 D0 00 13 88 7B 3E (set 1Ω, 20A, 5kW)

Rtn.:3C 01 07 **73 61** DC 3E(7bytes)

No.	0	1	2	Total
Bytes	3	3	3	9
Position	5-7	8-10	11-13	
Explain	Set resistance(unit 0.01Ω)	Set current	Set power	

Table I.2.5.SA Set/Query load parameter

I.2.5.SS Set hardware OVP, only the ready state can be executed

Receive command format:3C 01 0A **53 53** X*3 X 3E (10bytes) (3bytes OVP value,range:1.1 times the upper voltage limit)

Rec.:3C 01 0A **53 53** 00 22 60 33 3E (Set 88.00V)

Rtn.:3C 01 07 **73 73** EE 3E (7bytes)

I.1.5.SZ Set soft rise, only the ready state can be executed

Receive command format:3C 01 0A **53 5A** X*2 X 3E (9bytes) (2bytes soft rise,range:0.0~99.9S)

Rec.:3C 01 09 **53 5A** 00 64 1B 3E (Set 10.0S)

Rtn.:3C 01 07 **73 7A** F5 3E (7bytes)

I.1.5.SY Set system parameters (alarm, range, soft rise)

Query of setting command can be executed normally in the communication state.

I.2.5.GN Query setting source parameters

Rec.:3C 01 07 **47 4E** 9D 3E (7bytes)

Return command format:3C 01 10 **67 6E** X*9 X 3E (16bytes)

(Parameters are defined in Table I.2.5.SN)

Rtn.:3C 01 10 **67 6E** 00 15 7C 00 12 C0 00 09 C4 16 3E (55V, 48A, 2.5kW)

I.2.5.GT Query setting source bidirectional parameters

Rec.:3C 01 07 **47 54** A3 3E (7bytes)

Return command format:3C 01 16 **67 54** X*15 X

3E(22bytes)(Parameters are defined in Table I.2.5.ST)

Rtn.:3C 01 16 **67 74** 00 15 7C 00 12 C0 00 09 C4 00 0B B8 00 07 D0 BC 3E(55V,+48A,+2.5kW, -30A, -2kw)

I.2.5.GL Query setting list step parameters

Rec.:3C 01 09 **47 4C** X (Seq.)X (Step)X 3E (9bytes)

Rec.:3C 01 09 **47 4C** 02 00 9F 3E (**Query setting list seq.**2 step 0)

Return command format:3C 01 1D 67 6C X*22 X 3E (29bytes)

(Parameters are defined in Table I.2.5.SL)

Rtn.:3C 01 1D **67 6C** 02 00 00 00 0B B8 00 1B 58 00 0F A0 00 01 75 30 01 00 00 00 00 00 7F 3E (30V, 70A, 4kW, 1min30sec, no loop, next)

I.2.5.GV Query setting SAS parameters

Rec.:3C 01 07 **47 56** A5 3E (7bytes)

Return command format:3C 01 13 **67 76** X*12 X 3E (19bytes)

(Parameters are defined in Table I.2.5.SV)

Rtn.:3C 01 13 67 76 00 19 64 00 17 70 00 07 D0 00 05 DC AD 3E (Voc65.00V, Vmp60.00V, Isc20.00A, Imp15.00A)

I.2.5.GE Query setting EN50530 parameters

Rec.:3C 01 07 **47 45** 94 3E (7bytes)

Return command format:3C 01 10 **67 65** X*9 X 3E (16bytes)

(Parameters are defined in Table I.2.5.SE)

Rtn.:3C 01 10 67 65 03 E8 00 75 30 00 05 DC 00 4E 3E (Irr1000W/m², Vmp600.00V, Pmp3.000kW, cSi)

I.2.5.GD Query setting Sandia parameters

Rec.:3C 01 07 **47 44** 93 3E (7bytes)

Return command format:3C 01 14 **67 64** X*13 X 3E (20bytes)

(Parameters are defined in Table I.2.5.SD)

Rtn.:3C 01 14 67 64 03 E8 03 19 19 00 75 30 00 05 DC 00 00 86 3E (Irr1000W/m², IrrREF1000W/m², TC25°C, TREF25°C, Vmp300.00V, Pmp1.500kW, TF)

I.2.5.GG Query setting PV parameters

Rec.:3C 01 07 **47 47** 96 3E (7bytes)

Return command format:3C 01 0E **67 67** X*5 X 3E (14bytes)

(Parameters are defined in Table I.2.5.SG)

Rtn.:3C 01 0C 67 67 01 03 E8 02 05 CE 3E (CC, 1000Hz, Speed 2, Margin 5%)

I.2.5.GB Query setting battery simulation parameters

Rec.:3C 01 07 **47 42** 91 3E (7bytes)

Return command format:3C 01 1E **67 62** X*23 X 3E (30bytes)

(Parameters are defined in Table I.2.5.SG)

Rtn.:3C 01 1E **67 62** 00 00 64 00 00 00 00 00 00 00 00 0A 00 0A 01 F4 00 64 00 64 01 01 1F 3E (Same as I.2.5.SB setting parameters)

I.2.5.GO Query setting battery simulation SOC parameters

Rec.:3C 01 07 **47 4F** 9E 3E (7bytes)

Return command format:3C 01 0E **67 6F** X*22 X 3E (29bytes) (The specific parameter is 2 bytes 1 group, the first group represents SOC0%, the first group represents SOC10%, and so on, the unit is 0.01V, and the value is required to be in ascending order)

Rtn.:3C 01 1D **67 6F** 01 3B 01 66 01 6E 01 72 01 75 01 78 01 7B 01 7E 01 81 01 87 01 A1 0F 3E (An ascending array)

I.2.5.GC Query setting battery charge and discharge parameters

Rec.:3C 01 07 **47 43** 92 3E (7bytes)

Return command format:3C 01 26 **67 63** X*31 X 3E (38byte)

(Parameters are defined in Table I.2.5.SC)

Rtn.:3C 01 26 67 63 01 15 7C 14 00 03 E8 02 58 00 0A 01 00 0C 00 01 00 64 03 E8 27 10 0E D8 01 00 12 00 01 00 32 A6 3E

I.2.5.GA Query setting load parameters

Rec.:3C 01 07 **47 41** 90 3E (7bytes)

Return command format:3C 01 10 **67 61** X*9 X 3E (16bytes)

(Parameters are defined in Table I.2.5.SA)

Rtn.:3C 01 10 **67 61** 00 00 64 00 07 D0 00 13 88 AF 3E (1Ω, 20A, 5kW)

I.2.5.GS Query setting hardware OVP

Rec.:3C 01 07 **47 53** A2 3E (7bytes)

Return command format:3C 01 0A **67 73** X*3 X 3E (10bytes) (3bytes OVP value)

Rtn.:3C 01 0A **67 73** 00 22 60 67 3E (88.00V)

I.2.5.GZ Query setting soft rise

Rec.:3C 01 07 **47 5A** A9 3E (7bytes)

Return command format:3C 01 09 **67 7A** X*2 X 3E (9bytes) (2bytes soft rise unit:0.1S)

Rtn.:3C 01 09 **67 7A** 03 DE CC 3E(99.0S)

I.2.5.e3 Execution error (The current status cannot execute the receive command)

Rec.:3C 01 07 **43 50** 9B 3E (7bytes) (The stop command is sent in ready mode)

Rtn.:3C 01 0B **65 73** 43 50 00 00 77 3E (11bytes) (The ready state execution error)

Rec.:3C 01 07 **43 50** 9B 3E (7bytes) (The alarm mode sends a stop command)

Rtn.:3C 01 0B **65 73** 43 50 00 03 7A 3E (11bytes) (The alarm code is 03)

I.2.5.e4 Parameter error (Parameters out of range or conflicting parameters cannot be set)

Rec.:3C 01 10 **53 4E** 00 17 70 01 5F 90 00 09 C4 F6 3E (17bytes) (This command is used to set general parameter 1000A)

Rtn.:3C 01 0B **65 72** 53 4E 00 01 85 3E (11bytes) (The parameter is out of range. The error number is 1. You can see in Table I.2.5.SN that the current parameter is out of range.)

I.2.5.e5 Length error (Receive command Length error)

Rec.:3C 01 08 **43 50** 00 9C 3E (Incorrect receive command 8bytes)

Rtn.:3C 01 0B **65 6C** 43 50 08 07 7F 3E(11bytes) (The command length is incorrect, the actual incorrect receive command is 8bytes, and the correct receive command is 7bytes)

Modbus Communication Protocol (RTU and TCP)

The ModbusRTU protocol has CRC verification, so it is suitable for RS232 and RS485 interfaces.

The ModbusTCP protocol has no verification. Therefore, it is suitable for interfaces that have their own verification mechanism, such as LAN interfaces.

Modbus communication agreement

A) ModbusRTU Information frame format

- 1) Read the register value, function code 0x03 or 0x04

Host request		Slave response	
Slave Address	1byte	Slave Address	1byte
Function code 0x03	1byte	Function code 0x03	1byte
Start address high byte	1byte	Data length (2* number of registers)	1byte
Start address low byte	1byte		
Number of registers high byte	1byte	The first register data	2byte
Number of registers Low byte	1byte	
CRC check sum low byte	1byte	CRC check sum low byte	1byte
CRC check sum high byte	1byte	CRC check sum high byte	1byte

- 2) Presets a single register value, function code 0x06

Host request		Slave response	
Slave Address	1byte	Slave Address	1byte
Function code 0x06	1byte	Function code 0x06	1byte
Register address high byte	1byte	Register address high byte	1byte
Register address low byte	1byte	Register address low byte	1byte
Register data high byte	1byte	Register data high byte	1byte
Register data low byte	1byte	Register data low byte	1byte
CRC check sum low byte	1byte	CRC check sum low byte	1byte
CRC check sum high byte	1byte	CRC check sum high byte	1byte

3) Preset multiple register values, function code 0x10

Host request		Slave response	
Slave Address	1byte	Slave Address	1byte
Function code 0x10	1byte	Function code 0x10	1byte
Start address high byte	1byte	Register address high byte	1byte
Start address low byte	1byte	Register address low byte	1byte
Number of registers high byte	1byte	Number of registers high byte	1byte
Number of registers Low byte	1byte	Number of registers Low byte	1byte
Data length (2* number of registers)	1byte	CRC check sum low byte	1byte
The first register data high byte	1byte	CRC check sum high byte	1byte
The first register data low byte	1byte		
.....			
CRC check sum low byte	1byte		
CRC check sum high byte	1byte		

4) Abnormal response

Abnormal response	
Slave Address	1byte
Function code (Function code+0x80)	1byte
Exception code (01,02,03,04)	1byte
CRC check sum low byte	1byte
CRC check sum high byte	1byte

B) ModbusTCP Information frame format

1) Read the register value, function code 0x03 or 0x04

Host request		Slave response	
Transaction Identifier Range: 0000~FFFF	2byte	Transaction Identifier Same as the sent value	2byte
Protocol Identifier Fix to 0x00 0x00	2byte	Protocol Identifier Fix to 0x00 0x00	2byte
Length	2byte	Length	2byte
Slave Address	1byte	Slave Address	1byte
Function code 0x03	1byte	Function code 0x03	1byte

Start address high byte	1byte	Data length (2* number of registers)	1byte
Start address low byte	1byte		
Number of registers high byte	1byte	The first register data	2byte
Number of registers Low byte	1byte	

2) Presets a single register value, function code 0x06

Host request		Slave response	
Transaction Identifier Range: 0000~FFFF	2byte	Transaction Identifier Same as the sent value	2byte
Protocol Identifier Fix to 0x00 0x00	2byte	Protocol Identifier Fix to 0x00 0x00	2byte
Length	2byte	Length	2byte
Slave Address	1byte	Slave Address	1byte
Function code 0x06	1byte	Function code 0x06	1byte
Register address high byte	1byte	Register address high byte	1byte
Register address low byte	1byte	Register address low byte	1byte
Register data high byte	1byte	Register data high byte	1byte
Register data low byte	1byte	Register data low byte	1byte

3) Preset multiple register values, function code 0x10

Host request		Slave response	
Transaction Identifier Range: 0000~FFFF	2byte	Transaction Identifier Same as the sent value	2byte
Protocol Identifier Fix to 0x00 0x00	2byte	Protocol Identifier Fix to 0x00 0x00	2byte
Length	2byte	Length	2byte
Slave Address	1byte	Slave Address	1byte
Function code 0x10	1byte	Function code 0x10	1byte
Start address high byte	1byte	Register address high byte	1byte
Start address low byte	1byte	Register address low byte	1byte
Number of registers high byte	1byte	Number of registers high byte	1byte
Number of registers Low byte	1byte	Number of registers Low byte	1byte
Data length (2* number of registers)	1byte		
The first register data high byte	1byte		
The first register data low byte	1byte		
.....			

4) Abnormal response

Abnormal response	
Transaction Identifier, Same as the sent value	2byte
Protocol Identifier, Fix to 0x00 0x00	2byte
Length	2byte
Slave Address	1byte
Function code(Function code+0x80)	1byte
Exception code(01,02,03,04)	1byte
CRC check sum low byte	1byte
CRC check sum high byte	1byte

C) Exception handling

After receiving an exception or error data frame, the slave machine returns an exception response frame. The exception code is defined as follows.

Exception code	Implication	Remark
0x00	No exception	
0x01	Function code not supported	
0x02	The data address is invalid	
0x03	Illegal data	Parameter out of range or parameter conflict (such as photovoltaic)
0x04	Power state does not conform to	The current state is not allowed to execute the order received, reply the error code

When a CRC check error, address error, or function code error occurs in the data frame sent from the host to the slave, the slave does not respond to the host, and the host resends the frame according to timeout.

If a CRC check error, address error, or function code error occurs in a data frame sent from the slave computer to the host, the data frame is discarded. The host can resend the data frame for re-query or preset parameters.

At least 40 ms of rest time is reserved between the two frames of data, which is used to judge the completion of data frame reception and command processing within the power supply product.

D) Data format

All data formats are represented by hexadecimal numbers, and the word length of each register is 16 bits (2 bytes), for example:

- 1) Voltage value 100.00 V, expressed in hexadecimal as 0x2710.
- 2) Current value 18.00 A, expressed in hexadecimal as 0x0708.
- 3) Power value 3.500 kW, expressed in hexadecimal as 0x0DAC.



The voltage, current and power are all 16-bit data, and the data higher than 16-bit will be processed according to the down-bit. For example, the voltage of the 750 model is 750.00 V, and the actual data of 75000 exceeds 16 bits, the communication protocol processing accuracy will be changed to 0.1 V and the data will be changed to 7500 for processing.

Voltage setting and sampling resolution of 550 V and below is 0.01 V, and above 550 V is 0.1 V;

Current setting and sampling resolution for models 550 A and below is 0.01 A, and above 550 A is 0.1 A;

Power setting and sampling resolution for 55 kW and below models is 0.001 kW, and above 55 kW is 0.01 kW.

Definition of Modbus communication register

The following is an address assignment. Write indicates the operation of the host to the slave data store or preset, and read indicates the operation of querying the slave.

The address not specified is an empty address, and an address error is returned. An address error is returned by writing to a read-only address or reading to a write-only address.

Part of the address content is the same due to product improvement, in order to ensure that the previous version is consistent, so the same content is retained, such as address 0x0002 and 0x0020 and the following 4 bytes are the same.

1) Power status register: read-only

Address Dec	Address Hex	Read/Write	Description	Remark
0	0x0000	Read	Bit15: Current/power symbol bit,1 indicates a negative number Bit8: 1 alarm,0 normal Bit2: 1 sequence pause,0 non-sequence pause Bit1: 1 Start slow rise,0 not start slow rise Bit0: 1 Start,0 ready	
1	0x0001	Read	Alarm code, the non-alarm state is read as 0	
2	0x0002	Read	Power output state: 0 ready, 1 running, 2 CV, 3 CC, 4 CP, 5 PV state.	
3	0x0003	Read	Output voltage measurement value(V) Unit:0.01/0.1	
4	0x0004	Read	Absolute value of output current measurement(A) Unit:0.01/0.1	
5	0x0005	Read	Absolute value of output power measurement(kW) Unit:0.001/0.01	
6	0x0006	Read	Mpp instantaneous efficiency of PV operating state, unit 0.1%, other states return 0	
16	0x0010	Read	Upper limit of voltage,Unit:1V	
17	0x0011	Read	Upper limit of current,Unit:1A	
18	0x0012	Read	Upper limit of power,Unit:0.1kW	
19	0x0013	Read	Voltage communication numerical unit decimal point. For example, 0.1V is 1; 0.01 is 2	
20	0x0014	Read	Current communication numerical unit decimal point. For example, 0.1A is 1; 0.01 is 2	
21	0x0015	Read	Power communication numerical unit decimal point. For example, 0.01kW is 2; 0.001kW is 3	
22	0x0016	Read	Parallel count	

48	0x0030	Read	List running state: High byte - the sequence of the current running, Low byte - the step of the current running	The list running state is valid, and other states return 0
49	0x0031	Read	List running state: number of remaining cycles	
50	0x0032	Read	List running state: The higher 16 bits of the remaining time of the current step. Unit:0.1s	
51	0x0033	Read	List running state: The lower 16 bits of the remaining time of the current step. Unit:0.1s	
64	0x0040	Read	PV running curve actual Voc value(V) Unit:0.01/0.1	The PV running state is valid, and other states return 0
65	0x0041	Read	PV running curve actual Vmp value(V) Unit:0.01/0.1	
66	0x0042	Read	PV running curve actual Isc value(A) Unit:0.01/0.1	
67	0x0043	Read	PV running curve actual Imp value(A) Unit:0.01/0.1	
68	0x0044	Read	PV running curve actual Pmp value(kW) Unit:0.001/0.01	
80	0x0050	Read	Battery simulation current SOC, unit 0.1%	The battery simulation running/running end state is valid, and other states return 0
81	0x0051	Read	Battery simulation cumulative Ah change (with symbol), unit Ah	
82	0x0052	Read	Battery simulation cumulative Ah change time, unit 0.1h	
96	0x0060	Read	Battery charge and discharge cumulative Ah (with symbol), unit Ah	The battery charge and discharge running/running end state is valid, and other states return 0
97	0x0061	Read	Battery charge and discharge cumulative Wh (with symbol), unit Wh	
98	0x0062	Read	Battery charge and discharge cumulative time, unit 0.1h	

2) Control register: Only 0x06 can be used to write to a single register when setting

Address Dec	Address Hex	Read/Write	Description
512	0x0200	Read/Write	Read 0 indicates the power supply is ready state, read 1 indicates the power supply is running. Write 0 to stop power output, write 1 to start power output
513	0x0201	Read/Write	Read 0 indicates that the power supply does not alarm, read 1 indicates that the power supply alarm Write 0 to stop the alarm, write 1 no operation
514	0x0202	Write	List control: Power off: 0x0000 Power on: high byte 0x01; low byte list sequence Power on by single step: high byte 0x02; low byte list sequence Pause: 0x1000, Continue:0x1100
		Read	List status: Ready 0x0000, Running 0x0001, Pause 0x1000 Not list state 0xFFFF
515	0x0203	Read/Write	Power mode (ready state can be set) Source 0x4E00 Source bidirectional parameters 0x4E54 List height byte 0x4C; The low byte indicates the sequence number 0-49. 0xFF indicates that the sequence number of the current power supply remains unchanged Photovoltaic high byte 0x56; Low bytes 0x00/0x56:SAS mode, Low bytes 0x45:EN50530 mode, Low bytes 0x44:Sandia mode Battery simulation ready/running/running end 0x4200 Battery charge and discharge ready/running/running end 0x4300

			Load 0x4100 Other 0xFFFF, write will switch to the main menu
516	0x0204	Read/Write	Set Hardware OVP, ready state can be set
517	0x0205	Read/Write	Soft rise, ready state can be set
752	0x02F0	Write	Write 1: The battery simulation control generates the SOC sequence by voltage upper and lower limits and standard voltages

3) Parameter register: source parameters

Address Dec	Address Hex	Read/Write	Description
1024	0x0400	Read/Write	Set source voltage(V) Unit:0.01/0.1
1025	0x0401	Read/Write	Set source current(A) Unit:0.01/0.1
1026	0x0402	Read/Write	Set source power(kW)Unit:0.001/0.01



Note

The ready state write operation is switched to the source mode; The running state write operation can be adjusted online.

Address Dec	Address Hex	Read/Write	Description
1056	0x0420	Read/Write	Set source voltage(V) Unit:0.01/0.1
1057	0x0421	Read/Write	Set source positive current(A) Unit:0.01/0.1
1058	0x0422	Read/Write	Set source positive power (kW)Unit:0.001/0.01
1059	0x0423	Read/Write	Set source negative current (A) Unit:0.01/0.1
1060	0x0424	Read/Write	Set source negative power (kW)Unit:0.001/0.01



Note

The ready state write operation is switched to the source bidirectional parameter mode; The source bidirectional parameter running state write operation can be adjusted online.

4) Parameter register: list parameters, write step parameters can only be written all at once by 0x10.

The first 12 digits of the address (0x100 to 0x4E7) indicate the sequence and step number, which are calculated as $0x100 + \text{sequence number} * 20 + \text{step number}$.

If the representation of the first 12 bits of step 3 of the 19 sequence is calculated as $0x100+19*20+3=0x27F$, the address of parameter 1 of this step is 0x27F1.

The parameters of step 0 in sequence 0 are described as follows. Other sequence steps correspond to the first 12 bits of the modified address Hex.

Address Dec	Address Hex	Read/ Write	Description			
4096	0x1000	Read/ Write	Mode	0 UIP	1 U-Ramp	2 I-Ramp
4097	0x1001	Read/Write	Para1	Voltage	Voltage begin	Current begin
4098	0x1002	Read/Write	Para2	Current	Voltage end	Current end
4099	0x1003	Read/Write	Para3	Power	Current	Voltage
4100	0x1004	Read/Write	Time-hour, Range: 0-99h,			
4101	0x1005	Read/Write	Time-Minute: Range:0-59m			
4102	0x1006	Read/Write	Time-Second: Unit:0.001s Range:0.01~59.999s			
4103	0x1007	Read/Write	Step enable: 0 disable, 1 enable, 2 run and pause			
4104	0x1008	Read/Write	Loop set: 0 no loop, 1 loop begin, 2 loop end			
4105	0x1009	Read/Write	Loop count: Range: 0-9999			
4106	0x100A	Read/Write	Operation: 0 next step, 1 stop, 2 jump list sequence			
4107	0x100B	Read/Write	When Operation is 2:jump list sequence Range:0-49			



Note

1. Because the step parameters are related, all the parameters of the step must be written at one time before the operation. Only the 0x10 command is supported.
2. Read parameters can read any number of parameters within one step, but cannot be read by step.
3. Only the ready state can be written, and the ready state can be switched to the list mode.

5) Parameter register: PV setting parameters

Address Dec	Address Hex	Read/Write	Description
1536	0x0600	Read/Write	Search model 0-CV ; 1-CC
1537	0x0601	Read/Write	Filter
1538	0x0602	Read/Write	Speed
1539	0x0603	Read/Write	Margin



Note

1. Write operation can be performed only in ready state, and the write operation in ready state is switched to photovoltaic mode.
2. Only valid for power supply with photovoltaic mode, otherwise the address error will be returned.

6) Parameter register: PV SAS parameters, write parameters can only be written all at once by 0x10

Address Dec	Address Hex	Read/Write	Description
1552	0x0610	Read/Write	Set Voc
1553	0x0611	Read/Write	Set Vmp
1554	0x0612	Read/Write	Set Isc
1555	0x0613	Read/Write	Set Imp



Note

1. The ready state write operation is switched to the photovoltaic SAS mode; The running state write operation can be adjusted online.
2. Only valid for power supply with photovoltaic mode, otherwise the address error will be returned

7) Parameter register: PV EN50530 parameters, write parameters can only be written all at once by 0x10

Address Dec	Address Hex	Read/Write	Description
1568	0x0620	Read/Write	Set Irr
1569	0x0621	Read/Write	Set Vmp
1570	0x0622	Read/Write	Set Pmp
1571	0x0623	Read/Write	Set FF 0-cSi;1-TF



Note

1. The ready state write operation is switched to the photovoltaic EN50530 mode; The running state write operation can be adjusted online.
2. Only valid for power with PV mode, otherwise the address error will be returned

8) Parameter register: PV Sandia parameters, write parameters can only be written all at once by 0x10

Address Dec	Address Hex	Read/Write	Description
1584	0x0630	Read/Write	Set Irr
1585	0x0631	Read/Write	Set IrrREF
1586	0x0632	Read/Write	Set TC
1587	0x0633	Read/Write	Set TREF
1588	0x0634	Read/Write	Set Vmp
1589	0x0635	Read/Write	Set Pmp
1590	0x0636	Read/Write	Set FF 0-TF;1-SCMC;2-HEC



Note

1. The ready state write operation is switched to the photovoltaic Sandia mode; The running state write operation can be adjusted online.
2. Only valid for power with PV mode, otherwise the address error will be returned.

9) Parameter register: Batter simulation parameters, write parameters can only be written all at once by 0x10

Address Dec	Address Hex	Read/Write	Description
1792	0x0700	Read/Write	Battery type 2
1793	0x0701	Read/Write	Battery Capacity, unit 0.1Ah
1794	0x0702	Read/Write	Internal resistance, unit 0.001Ω
1795	0x0703	Read/Write	Battery upper voltage, unit 0.01V
1796	0x0704	Read/Write	Battery standard voltage, unit 0.01V
1797	0x0705	Read/Write	Battery lower voltage, unit 0.01V
1798	0x0706	Read/Write	Serial no.
1799	0x0707	Read/Write	Parallel no.
1800	0x0708	Read/Write	Soc initial, unit 0.1%
1801	0x0709	Read/Write	Charge Imax

1802	0x070A	Read/Write	Discharge Imax
1803	0x070B	Read/Write	SOC reach limit 0 Limit 1 stop
1804	0x070C	Read/Write	Curve Shows 0 Discharge 1 Charge



Note

1. Write operation can be performed only in ready state, and the write operation in ready state is switched to battery simulation mode.
2. 0 Lithium manganese LMO, 1 lithium cobaltate LCO, 2 lithium iron phosphate LFO, 3 ternary lithium NCM, 4 Lithium Titanate LTO, 5 lead-acid battery Pb, 6 NiMH battery, 7 NiCd battery, 8 custom battery.

10)Parameter register: Battery simulation SOC parameters, write parameters can only be written all at once by 0x10

Address Dec	Address Hex	Read/Write	Description
1808	0x0710	Read/Write	SOC0%, unit 0.01V
1809	0x0711	Read/Write	SOC10%, unit 0.01V
1810	0x0712	Read/Write	SOC20%, unit 0.01V
1811	0x0713	Read/Write	SOC30%, unit 0.01V
1812	0x0714	Read/Write	SOC40%, unit 0.01V
1813	0x0715	Read/Write	SOC50%, unit 0.01V
1814	0x0716	Read/Write	SOC60%, unit 0.01V
1815	0x0717	Read/Write	SOC70%, unit 0.01V
1816	0x0718	Read/Write	SOC80%, unit 0.01V
1817	0x0719	Read/Write	SOC90%, unit 0.01V
1818	0x071A	Read/Write	SOC100%, unit 0.01V



Note

The ready state write operation is switched to the battery simulation mode.

11)Parameter register: Batter charge and discharge parameters

Address Dec	Address Hex	Read/Write	Description
1920	0x0780	Read/Write	Mode : 0 discharge 1 charge
1921	0x0781	Read/Write	Battery OVP
1922	0x0782	Read/Write	Charge voltage

1923	0x0783	Read/Write	Charge current
1924	0x0784	Read/Write	Charge power
1925	0x0785	Read/Write	Charge cutoff current
1926	0x0786	Read/Write	Charge cutoff time switch: 0off 1on
1927	0x0787	Read/Write	Charge cutoff time hour
1928	0x0788	Read/Write	Charge cutoff time minute
1929	0x0789	Read/Write	Charge cutoff time second
1930	0x078A	Read/Write	Charge cutoff Ah switch
1931	0x078B	Read/Write	Charge cutoff Ah , unit 0.1Ah
1932	0x078C	Read/Write	Discharge current
1933	0x078D	Read/Write	Discharge power
1934	0x078E	Read/Write	Discharge cutoff voltage
1935	0x078F	Read/Write	Discharge cutoff time switch: 0off 1on
1936	0x0790	Read/Write	Discharge cutoff time hour
1937	0x0791	Read/Write	Discharge cutoff time minute
1938	0x0792	Read/Write	Discharge cutoff time second
1939	0x0793	Read/Write	Discharge cutoff Ah switch
1940	0x0794	Read/Write	Discharge cutoff Ah, unit 0.1Ah



Note

The ready state write operation is switched to the battery charge and discharge mode.

12)Parameter register: load parameters, write parameters can only be written all at once by 0x10

Address Dec	Address Hex	Read/Write	Description
2048	0x0800	Read/Write	Set load resistance high 16bit, Unit:0.01Ω
2049	0x0801	Read/Write	Set load resistance low 16bit, Unit:0.01Ω
2050	0x0802	Read/Write	Set load current(A) Unit:0.01/0.1
2051	0x0803	Read/Write	Set load power(kW)Unit:0.001/0.01



Note

The ready state write operation is switched to the load mode; The load running state write operation can be adjusted online.

Examples of Modbus Communication Commands

Rec. Indicates an Example for receive commands.

Rtn. Indicates an Example for return commands.

Power off

Rec.: 01 06 02 00 00 00 88 72

Rtn.: 01 06 02 00 00 00 88 72

Power on

Rec.: 01 06 02 00 00 01 49 B2

Rtn.: 01 06 02 00 00 01 49 B2

Alarm exit

Rec.: 01 06 02 01 00 00 D9 B2

Rtn.: 01 06 02 01 00 00 D9 B2

Query power status and alarm code

Rec.: 01 03 00 00 00 02 C4 0B

Query power status

Rec.: 01 03 00 00 00 06 C5 C8

Query power status with PV MPP efficiency query

Rec.: 01 03 00 00 00 07 04 08

Query the upper limit of voltage, current and power

Rec.: 01 03 00 10 00 03 04 0E

Query voltage, current, power upper limit and data decimal point and so on

Rec.: 01 03 00 10 00 07 05 CD

Query power output status and measured value

Rec.: 01 03 00 20 00 04 45 C3

Query list running state

Rec.: 01 03 00 30 00 04 44 06

Query PV running parameter

Rec.: 01 03 00 40 00 05 84 1D

Query Battery simulation running parameter

Rec.: 01 03 00 50 00 03 05 DA

Query Battery charge and discharge running parameter

Rec.: 01 03 00 60 00 03 05 D5

Query control register parameter

Rec.: 01 03 02 00 00 06 C4 70

Set source mode

Rec.: 01 06 02 03 4E 00 4D D2

Set source bidirectional parameters mode

Rec.: 01 06 02 03 4E 54 4C 2D

Set load mode

Rec.: 01 06 02 03 41 00 48 22

Set list mode and sequence 1

Rec.:01 06 02 03 4C 01 8D 72

Set PV SAS mode

Rec.: 01 06 02 03 56 56 C7 EC

Set PV EN50530mode

Rec.: 01 06 02 03 56 45 86 21

Set PV Sandia mode

Rec.: 01 06 02 03 56 44 47 E1

Set Battery simulation mode

Rec.: 01 06 02 03 42 00 48 D2

Set battery simulation SOC parameters through the battery voltage range

Rec.: 01 06 02 F0 00 01 49 81

Set Battery charge and discharge mode

Rec.: 01 06 02 03 43 00 49 42

Read source setting

Rec.:01 03 04 00 00 03 04 FB

Write source setting

Rec.:01 10 04 00 00 03 06 13 88 03 E8 03 E8 91 C2 (Models 550V and below, 50V, 10A, 1kw)

Rec.:01 10 04 00 00 03 06 01 F4 03 E8 03 E8 C3 7A (Models above 550V, 50V, 10A, 1kw)

Read source bidirectional parameters setting

Rec.:01 03 04 20 00 05 85 33

Write source bidirectional parameters setting

Rec.:01 10 04 20 00 05 0A 13 88 03 E8 03 E8 07 D0 07 D0 98 99 (Models 550V and below, 50V, +10A, +1kw, -20A, -2kw)

Read load setting

Rec.:01 03 08 00 00 04 46 69

Write load settingRec.:01 10 08 00 00 04 08 00 00 00 64 07 D0 13 88 D5 21 (1 Ω , 20A, 5kw)**Read list parameter**

Rec.:01 03 24 30 00 0C 4F 30 (list sequence 16 step 3)

Write list parameterRec.:01 10 24 30 00 0C 18 00 02 01 F4 01 90 01 2C 00 01 00 02 13 88 00 02 00 01 03 E7 00 02 00 05 8A 4A (Models 550V and below, list sequence 16 step 3 I ramp 5A \rightarrow 4A, 3V, 1 hour 2 minute 5 second, run and pause, loop begin, loop count 999, jump sequence 5)**Read PV setting parameter**

Rec.:01 03 06 00 00 04 44 81

Write PV setting parameter

Rec.:01 10 06 00 00 04 08 00 01 00 00 00 02 00 05 CE BF (CC, 0Hz,
speed 2, margin5%)

Read PV SAS parameter

Rec.:01 03 06 10 00 04 45 44

Write PV SAS parameter

Rec.:01 10 06 10 00 04 08 01 F4 01 C2 03 E8 03 84 F2 A3 (Models
above 550V, 50V, 45V, 10A, 9A)

Read PV EN50530 parameter

Rec.:01 03 06 20 00 04 45 4B

Write PV EN50530 parameter

Rec.:01 10 06 20 00 04 08 03 E8 01 F4 01 F4 00 01 27 D2 (Models above
550V, Irr1000, 50V, 0.5kW, TF)

Read PV Sandia parameter

Rec.:01 03 06 30 00 07 04 8F

Write PV Sandia parameter

Rec.:01 10 06 30 00 07 0E 03 E8 03 E8 00 19 00 19 01 F4 01 F4 00 01 87
FE (Models above 550V, Irr1000/1000, T25/ 25, 50V, 0.5kW, SCMC)

Read battery simulation parameters

Rec.:01 03 07 00 00 0D 85 7B

Write battery simulation parameters

Rec.:01 10 07 00 00 0D 1A 00 00 00 64 00 00 00 00 00 00 00 00 0A 00
0A 01 F4 00 64 00 64 00 01 00 01 27 FA (*Lithium manganate LMO*,
10Ah, 0Ω, 10 Serial 10 parallel, SOC initial 50%, I_{max} 1A, SOC limit
stop, charge curve display)

Read battery simulation SOC parameters

Rec.:01 03 07 10 00 0B 04 BC

Write battery simulation SOC parameters

Rec.:01 10 07 10 00 0B 16 01 3B 01 66 01 6E 01 72 01 75 01 78 01 7B 01
7E 01 81 01 87 01 A1 CB 66 (An ascending array)

Read battery charge and discharge parameters

Rec.:01 03 07 80 00 15 84 99

Write battery charge and discharge parameters

Rec.:01 10 07 80 00 15 2A 00 01 15 7C 14 00 03 E8 02 58 00 0A 00 01 00
00 00 0C 00 00 00 01 00 64 03 E8 27 10 0E D8 00 01 00 00 00 12 00 00 00
01 00 32 06 C1

Examples of ModbusR TCP Communication Commands

Rec. Indicates an Example for receive commands.

Rtn. Indicates an Example for return commands.

Power off

Rec.: 00 00 00 00 00 06 01 06 02 00 00 00

Rtn.: 00 00 00 00 00 06 01 06 02 00 00 00

Power on

Rec.00 00 00 00 00 06 01 06 02 00 00 01

Rtn. 00 00 00 00 00 06 01 06 02 00 00 01

Alarm exit

Rec.00 00 00 00 00 06 01 06 02 01 00 00

Rtn. 00 00 00 00 00 06 01 06 02 01 00 00

Query power status and alarm code

Rec.00 00 00 00 00 06 01 03 00 00 00 02

Query power status

Rec.00 00 00 00 00 06 01 03 00 00 00 06

Query power status with PV MPP efficiency query

Rec.00 00 00 00 00 06 01 03 00 00 00 07

Query the upper limit of voltage, current and power

Rec.00 00 00 00 00 06 01 03 00 10 00 03

Query voltage, current, power upper limit and data decimal point and so on

Rec.00 00 00 00 00 06 01 03 00 10 00 07

Query power output status and measured value

Rec.00 00 00 00 00 06 01 03 00 30 00 04

Query list running state

Rec.00 00 00 00 00 06 01 03 00 30 00 04

Query PV running parameter

Rec.00 00 00 00 00 06 01 03 00 40 00 05

Query Battery simulation running parameter

Rec.00 00 00 00 00 06 01 03 00 50 00 03

Query Battery charge and discharge running parameter

Rec.00 00 00 00 00 06 01 03 00 60 00 03

Query control register parameter

Rec.00 00 00 00 00 06 01 03 02 00 00 06

Set source mode

Rec.00 00 00 00 00 06 01 06 02 03 4E 00

Set source bidirectional parameters mode

Rec.:00 00 00 00 00 06 01 06 02 03 4E 54

Set load mode

Rec.00 00 00 00 00 06 01 06 02 03 41 00

Set list mode and sequence 1

Rec.00 00 00 00 00 06 01 06 02 03 4C 01

Set PV SAS mode

Rec.00 00 00 00 00 06 01 06 02 03 56 56

Set PV EN50530 mode

Rec.00 00 00 00 00 06 01 06 02 03 56 45

Set PV Sandia mode

Rec.00 00 00 00 00 06 01 06 02 03 56 44

Set Battery simulation mode

Rec. 00 00 00 00 00 06 01 06 02 03 42 00

Set battery simulation SOC parameters through the battery voltage range

Rec. 00 00 00 00 00 06 01 06 02 F0 00 01

Set Battery charge and discharge mode

Rec. 00 00 00 00 00 06 01 06 02 03 43 00

Read source setting

Rec.00 00 00 00 00 06 01 03 04 00 00 03

Write source setting

Rec.00 00 00 00 00 0D 01 10 04 00 00 03 06 13 88 03 E8 03 E8 (550V and below models, 50V, 10A, 1kw)

Rec.00 00 00 00 00 0D 01 10 04 00 00 03 06 01 F4 03 E8 03 E8 (550V and above models, 50V, 10A, 1kw)

Read source bidirectional parameters setting

Rec.:00 00 00 00 00 06 01 03 04 20 00 05 85 33

Write source bidirectional parameters setting

Rec.:00 00 00 00 00 11 01 10 04 20 00 05 13 88 03 E8 03 E8 07 D0 07 D0 (Models 550V and below, 50V, +10A, +1kw, -20A, -2kw)

Read load setting

Rec.00 00 00 00 00 06 01 03 08 00 00 04

Write load settingRec.00 00 00 00 00 0F 01 10 08 00 00 04 08 00 00 00 64 07 D0 13 88 (1 Ω , 20A, 5kw)**Read list parameter**

Rec.00 00 00 00 00 06 01 03 24 30 00 0C (Sequence 16 Step 3)

Write list parameter

Rec.00 00 00 00 00 1F 01 10 24 30 00 0C 18 00 02 01 F4 01 90 01 2C 00 01 00 02 13 88 00 02 00 01 03 E7 00 02 00 05

(Models 550V and below, list sequence 16 step 3 I ramp 5A \rightarrow 4A, 3V, 1 hour 2 minute 5 second, run and pause, loop begin, loop count 999, jump sequence 5)**Read PV setting parameter**

Rec.00 00 00 00 00 06 01 03 06 00 00 04

Write PV setting parameter

Rec.00 00 00 00 00 0F 01 10 06 00 00 04 08 00 01 00 00 00 02 00 05 (CC, 0Hz, speed 2, margin5%)

Read PV SAS parameter

Rec.00 00 00 00 00 06 01 03 06 10 00 04

Write PV SAS parameter

Rec.00 00 00 00 00 0F 01 10 06 10 00 04 08 01 F4 01 C2 03 E8 03 84
 (Models above 550V, 50V, 45V, 10A, 9A)

Read PV EN50530 parameter

Rec.00 00 00 00 00 06 01 03 06 20 00 04

Write PV EN50530 parameter

Rec.00 00 00 00 00 06 01 03 06 20 00 04

(Models above 550V, Irr1000, 50V, 0.5kW, TF)

Read PV Sandia parameter

Rec.00 00 00 00 00 06 01 03 06 30 00 07

Write PV Sandia parameter

Rec.00 00 00 00 00 15 01 10 06 30 00 07 0E 03 E8 03 E8 00 19 00 19 01
 F4 01 F4 00 01

(Models above 550V, Irr1000/1000, T25/25, 50V, 0.5kW, SCMC)

Read battery simulation parameters

Rec.00 00 00 00 00 06 01 03 07 00 00 0D

Write battery simulation parameters

Rec.00 00 00 00 00 21 01 10 07 00 00 0D 1A 00 00 00 64 00 00 00 00 00
 00 00 00 00 0A 00 0A 01 F4 00 64 00 64 00 01 00 01 (*Lithium manganate
 LMO, 10Ah, 0Ω, 10 Serial 10 parallel, SOC initial 50%, I_{max} 1A, SOC
 limit stop, charge curve display*)

Read battery simulation SOC parameters

Rec.00 00 00 00 00 06 01 03 07 10 00 0B 04

Write battery simulation SOC parameters

Rec.00 00 00 00 00 1D 01 10 07 10 00 0B 16 01 3B 01 66 01 6E 01 72 01
 75 01 78 01 7B 01 7E 01 81 01 87 01 A1 (An ascending array)

Read battery charge and discharge parameters

Rec.00 00 00 00 00 06 01 03 07 80 00 15

Write battery charge and discharge parameters

Rec.00 00 00 00 00 31 01 10 07 80 00 15 2A 00 01 15 7C 14 00 03 E8 02
 58 00 0A 00 01 00 00 00 0C 00 00 00 01 00 64 03 E8 27 10 0E D8 00 01
 00 00 00 12 00 00 00 01 00 32

CAN Communication Protocol

Instruction

PGN	All in PDU2 format, command range F600~F6FF
SA_DC	RB power address (configurable via power interface), range 1-250, sending command SA. SA_DC and SA_PC cannot be the same.
SA_PC	RB remote address (configurable via power interface), range 1-250, receiving command SA. SA_DC and SA_PC cannot be the same.
Byte Order	Inter
Baud Rate	250K/bps
Response	Responds only to command with PGN=F618, no response to other commands
Response Time	The normal response speed for commands is about 10ms



Note

1. The highest resolution for voltage is 0.01 V, and above 550 V, the highest resolution will drop to 0.1 V; the highest resolution for current is 0.01 A, and above 550 A, the highest resolution will change to 0.1 A; the highest resolution for power is 0.001kW, and above 55kW, the highest resolution will change to 0.01kW; the resolution for higher voltage, current, and power can be inferred by five significant figures, and the actual unit value can be obtained through the 'Query Power Range' communication command. Examples in the communication command details are all based on units of 0.01V, 0.01A, 0.001kW.
2. Photovoltaic related content is only valid when the photovoltaic function is turned on.
3. After executing the photovoltaic startup and online adjustment commands, due to the need to calculate the photovoltaic curve, there will be dozens of milliseconds when communication commands cannot be responded to.
4. In the examples below, the power reception example 06 and power transmission example 0D mean that the power address set in the protocol is 13, and the remote address is set to 6.

Command Syntax of CAN

Item	Priority	PGN	Source Address	ID Power receiving example 06 Power sending example 0D Bidirectional Parameter example xx	Command Direction	Time (ms) Command Cycle	Message Command	Byte (0-7) Byte	Signal Name	Signal Description	Signal Length (Bit)	Resolution	Offset	Signal Min. Value (physical)	Signal Max. Value (physical)	Initial Value	Unit	Signal Value Description	
1	6	F610	SA_PC	0x18F61006	Power Receive		Power Control	Byte0	ctDcOut	Power Start/ Stop Control Signal/ Cancel Alarm Signal	8	1	0	0	2	0		0x00 indicates to stop power output. 0xFF indicates to start power output. 0x0A indicates to cancel power alarm status (if cancellable). 0x10 indicates to start sequence step by step (only valid in list ready state). 0x11 indicates to pause sequence (only valid in list running state). 0x12 indicates to continue sequence (only valid in list paused state).	
2	6	F611	SA_PC	0x18F61106	Power Receive		Set Working Mode	Byte0	ctDcMode	Set Power Working Mode	8	1	0					ready state can be set: 0x10 indicates setting the power mode 0x12 indicates setting the power bidirectional parameter mode 0x20 indicates setting the list mode 0x30 indicates setting the PV SAS operating mode 0x31 indicates setting the PV EN50530 operating mode 0x32 indicates setting the PV Sandia operating mode 0x33 indicates setting the PV Table operating mode 0x34 indicates setting the PV SAS2 operating mode 0x40 indicates setting the battery simulation operating mode 0x50 indicates setting the charge-discharge operating mode 0x60 indicates setting the load operating mode	
								Byte1	ctDcModeListSeq	Set power serial number	8	1	0	0	49				When set to sequential operating mode, set the current sequence number
3	6	F612	SA_PC	0x18F61206	Power Receive		Set Auto Report	Byte0	ctDcReAutoMea	Set automatic sample return (PGN:F620)	8	1	0	0	1			1 indicates automatic transmission, 0 indicates turning off automatic transmission (power supply will reset to ON each time it is powered up)	
								Byte1	ctDcReAutoSta	Set automatic status return (PGN:F621)	8	1	0	0	1				
4	6	F618	SA_PC	0x18F61806	Power Receive		Query PGN	Byte0-1	ctDcGetPGN	Query setting PGN, valid PGNs are: F612 F620 and F621 are invalid when automatically returned All ≥ F630	16	1	0	0xF600	0xF6FF			Return the corresponding query value when the PGN is valid	
								Byte2	ctDcGetListSeq	Query serial number	8	1	0	0	49	0			Valid when the PGN is F640~F643 sequence command, otherwise fill in 0
								Byte3	ctDcGetListStep	Query serial step number	8	1	0	0	19	0			
5	6	F620	SA_DC	0x18F6200D	Power Send	100ms	Power Sampling Return (default periodic return, can be closed)	Byte0	reDcOutCState	Power steady state return value	8	1	0	0	5			0 indicates no output, 1 indicates output, 2 indicates CV state, 3 indicates CC state, 4 indicates CP state, 5 indicates PV state (photovoltaic)	
								Byte1-2	reDcOutVolMeasure	Power voltage sample return value	16	0.01	0	0		0	V	Range varies depending on the model	
								Byte3-5	reDcOutCurMeasure	Power current sample return value	24	0.01	0	0		0	A		
6	6	F621	SA_DC	0x18F6210D	Power Send	100ms	Power State Return (default periodic return, can be closed)	Byte0	reDcModeSta	Power status return value	8	1	0	0	255	10		0x10 indicates power mode ready state, 0x12 indicates power bidirectional parameter mode ready state.	
								Byte1-7	reDcModeStaPara	Power status parameter return value, see signal value description									0x90 indicates power mode output state, 0x92 indicates power bidirectional parameter mode output state, Byte1 indicates alarm prompt, Byte2-3 indicates output soft rise remaining time, unit 0.1S. 0x20 indicates list ready state, Byte1 indicates the current sequence number 0xA0 indicates list output state, Byte1 indicates alarm prompt, Byte2 current running sequence number, Byte3 current running step number, Byte4-6 indicates current step remaining time, unit 0.1s. 0xA1 indicates list paused state, same as output state description. 0x30 indicates photovoltaic ready state SAS, 0x31 indicates photovoltaic ready state EN50530, 0x32 indicates photovoltaic ready state Sandia, 0x33 indicates photovoltaic ready state Table, 0x34 indicates photovoltaic ready state SAS2, 0xB0 indicates photovoltaic output state, Byte1 indicates alarm prompt, Byte2-3 indicates output soft rise remaining time, unit 0.1S 0x0A indicates alarm state, Byte1 indicates alarm code 0x40 indicates battery simulation ready state, 0xC0 indicates battery

																		simulation running state, 0xC1 indicates battery simulation running end Byte1 indicates alarm prompt, byte2-3 indicates current Soc unit 0.1%, byte4-5 indicates Ah total unit 0.1Ah (note that negative numbers need to be padded with FF), byte6-7 indicates time total unit 0.1h 0x50 indicates charge-discharge ready state 0xD0 indicates charge-discharge running state, 0xD1 indicates charge-discharge running end, Byte1 indicates alarm prompt, byte2-3 indicates Ah total unit 0.1Ah, byte4-5 indicates Wh total unit 0.1Wh, byte6-8 indicates time total unit 0.1h 0xE0 indicates load working mode, 0xE0 indicates load working mode 0xFF indicates other states (such as menu state, etc.)
7	6	F630	SA_PC/ SA_DC	0x18F630xx	Bi-directional	Set/Query Setting Power Mode Voltage Current Power	Byte0-1	setDcPowVol/ getDcPowVol	Set/ query setting Power mode voltage	16	0.01	0	0			V	Setting will make all ready states valid and switch to power mode Setting will make output state only valid in power mode and can be adjusted online	
							Byte2-3	setDcPowCur/ getDcPowCur	Set/ query setting Power mode current	16	0.01	0	0		A			
							Byte4-5	setDcPowPow/ getDcPowPow	Set/ query setting Power mode power	16	0.001	0	0		kW			
8	6	F632	SA_PC/ SA_DC	0x18F632xx	Bi-directional	Set/Query Setting Power Bidirectional Parameter Mode Voltage Positive/Negative Current	Byte0-1	setDcBirPowVol/ getDcBirPowVol	Set/ query setting power bidirectional parameter mode voltage	16	0.01	0	0			V	Setting will make all ready states valid and switch to power bidirectional parameter mode Setting will make output state only valid in power bidirectional parameter mode and can be adjusted online	
							Byte2-3	setDcBirPowPosCur/ getDcBirPowPosCur	Set/ query setting power bidirectional parameter mode positive current	16	0.01	0	0		A			
							Byte4-5	setDcBirPowNegCur/ getDcBirPowNegCur	Set/ query setting power bidirectional parameter mode negative current	16	0.01	0	0		A			
9	6	F633	SA_PC/ SA_DC	0x18F633xx	Bi-directional	Set/Query Setting Power Bidirectional Parameter Mode Positive/Negative Power	Byte0-1	setDcBirPowPosPow/ getDcBirPowPosPow	Set/ query setting power bidirectional parameter mode positive power	16	0.001	0	0			kW		
							Byte2-3	setDcBirPowNegPow/ getDcBirPowNegPow	Set/ query setting power bidirectional parameter mode negative power	16	0.001	0	0		kW			
10	6	F638	SA_PC/ SA_DC	0x18F638xx	Bi-directional	Set/Query Setting Set OVP Value and Soft rise Value	Byte0-1	setDcSetOVP/ getDcSetOVP	Set/ query setting Set OVP value	16	0.01	0	1			V	Setting will make ready state valid	
							Byte2-3	setDcSetSoftRise/ getDcSetSoftRise	Set/ query setting Set Soft rise value	16	0.1	0	0	99.9	0	S		
11	6	F639	SA_PC/ SA_DC	0x18F639xx	Bi-directional	Set/Query Setting Maximum Voltage Current Power	Byte0-1	setDcLimitVol/ getDcLimitVol	Set/ query setting Power maximum voltage	16	0.01	0	0			V	Setting will make ready state valid, if the set value exceeds the maximum value under the mode, it will be changed to the maximum value (e.g., if the regular setting is 80V, and the maximum power supply voltage value is set to 60V, then the regular voltage will be automatically changed to 60V)	
							Byte2-3	setDcLimitCur/ getDcLimitCur	Set/ query setting Power maximum current	16	0.01	0	0		A			
							Byte4-5	setDcLimitPow/ getDcLimitPow	Set/ query setting Power maximum power	16	0.001	0	0		kW			
12	6	F63A	SA_DC	0x18F63A0D	Power Send	Query Setting Power Range Parameter 1	Byte1	getDcPointVol	Query power voltage decimal point	8	1	0	0				Unit decimal place offset position, taking voltage as an example, 0 indicates the unit is 1V, 1 indicates the unit is 0.1V, 2 indicates the unit is 0.01V.	
							Byte2-3	getDcRangeVol	Query power voltage range	16	0.01	0	0		V			
							Byte4	getDcPointCur	Query power current decimal point	8	1	0	0					
							Byte5-6	getDcRangeCur	Query power current range	16	0.01	0	0		A			

13	6	F63B	SA_DC	0x18F63B0D	Power Send	Query Setting Power Range Parameter 2	Byte0	getDcPointPow	Query power decimal point	8	1	0	0				
							Byte1-2	getDcRangePow	Query power range	16	0.001	0	0				kW
							Byte3	setDcParallelCnt	Query power parallel quantity	8	1	0	0				
							Byte4	setDcSolarFunc	Query if photovoltaic function is available	8	1	0	0				
14	6	F640	SA_PC/ SA_DC	0x18F640xx	Bi-directional	Set/Query Setting List Parameter 1	Byte0	setDcListSeq/ getDcListSeq	Set/ query setting List sequence number	8	1	0	0	49	0		
							Byte1	setDcListStep/ getDcListStep	Set/ query setting List step number	8	1	0	0	19	0		
							Byte2	setDcListMode/ getDcListMode	Set/ query setting List mode	8	1	0	0	2	0		
							Byte3	setDcListHour/ getDcListHour	Set/ query setting List time - hours	8	1	0	0	99	0		h
							Byte4	setDcListMinute/ getDcListMinute	Set/ query setting List time - minutes	8	1	0	0	59	0		m
							Byte5-6	setDcListSecond/ getDcListSecond	Set/ query setting List time - seconds	16	0.001	0	0	59.999	0		s
15	6	F641	SA_PC/ SA_DC	0x18F641xx	Bi-directional	Set/Query Setting List Parameter 2	Byte0	setDcListSeq/ getDcListSeq	Set/ query setting List sequence number	8	1	0	0	49	0		
							Byte1	setDcListStep/ getDcListStep	Set/ query setting List step number	8	1	0	0	19	0		
							Byte2-3	setDcListPara1/ getDcListPara1	Set/ query setting List Para1	16							
							Byte4-5	setDcListPara2/ getDcListPara2	Set/ query setting List Para2	16							
							Byte6-7	setDcListPara3/ getDcListPara3	Set/ query setting List Para3	16							
16	6	F642	SA_PC/ SA_DC	0x18F642xx	Bi-directional	Set/Query Setting List Parameter 3	Byte0	setDcListSeq/ getDcListSeq	Set/query setting List sequence number	8	1	0	0	49	0		
							Byte1	setDcListStep/ getDcListStep	Set/query setting List step number	8	1	0	0	19	0		
							Byte2	setDcListEnable/ getDcListEnable	Set/query setting List step enable	8	1	0	0	2	0		Step enable: 0 means disable step, 1 means enable step, 2 means pause after step completion
							Byte3	setDcListLoop/ getDcListLoop	Set/query setting List loop	8	1	0	0	2	0		Cycle: 0 means normal, 1 means start of cycle 2 means end of cycle
							Byte4-5	setDcListLoopCnt/ getDcListLoopCnt	Set/query setting List loop times	16	1	0	0	9999	0		
							Byte6	setDcListOper/ getDcListOper	Set/query setting List end operation	8	1	0	0	2	0		End operation: 0 means next step, 1 means stop, 2 means jump sequence
							Byte7	setDcListJumpSeq/ getDcListJumpSeq	Set/query setting List jump sequence	8	1	0	0	49	0		
17	6	F650	SA_DC	0x18F6500D	Power Send	Query Setting Operation Photovoltaic Actual Parameters (some models without photovoltaic function)	Byte0-1	getDcRunVoc	Query photovoltaic actual Voc value during operation	16	0.01	0	0				V
							Byte2-3	getDcRunVmp	Query photovoltaic actual Vmp value during operation	16	0.01	0	0				V
							Byte4-5	getDcRunIsc	Query photovoltaic actual Isc value during operation	16	0.01	0	0				A
							Byte6-7	getDcRunImp	Query photovoltaic actual Imp value during operation	16	0.01	0	0				A

18	6	F652	SA_PC/ SA_PC	0x18F652xx	Bi-directional	Set/Query Setting Photovoltaic SAS Mode Parameters (some models without photovoltaic function)	Byte0-1	setDcSasVoc/ getDcSasVoc	Set/query setting Photovoltaic SAS mode Voc value	16	0.01	0	0			V	Set all ready states to be valid and switch to photovoltaic Sas mode Set while active state only photovoltaic start state is valid
							Byte2-3	setDcSasVmp/ getDcSasVmp	Set/query setting Photovoltaic SAS mode Vmp value	16	0.01	0	0			V	
							Byte4-5	setDcSasIsc/ getDcSasIsc	Set/query setting Photovoltaic SAS mode Isc value	16	0.01	0	0			A	
							Byte6-7	setDcSasImp/ getDcSasImp	Set/query setting Photovoltaic SAS mode Imp value	16	0.01	0	0			A	
19	6	F654	SA_PC/ SA_PC	0x18F654xx	Bi-directional	Set/Query Setting Photovoltaic EN50530 Mode Parameters (some models without photovoltaic function)	Byte0-1	setDcEN50530Irr/ getDcEN50530Irr	Set/query setting Photovoltaic EN50530 mode Irr value	16	1	0	1	3000	1000		Set all ready states to be valid and switch to photovoltaic EN50530 mode, set while active state only photovoltaic start state is valid FF 0-cSi;1-TF
							Byte2-3	setDcEN50530Vmp/ getDcEN50530Vmp	Set/query setting Photovoltaic EN50530 mode Vmp value	16	0.01	0	0			V	
							Byte4-5	setDcEN50530Pmp/ getDcEN50530Pmp	Set/query setting Photovoltaic EN50530 mode Pmp value	16	0.001	0	0			kW	
							Byte6	setDcEN50530FF/ getDcEN50530FF	Set/query setting Photovoltaic EN50530 mode FF value	8		0	0				
20	6	F656	SA_PC/ SA_PC	0x18F656xx	Bi-directional	Set/Query Setting Photovoltaic Sandia Mode Parameters 1 (some models without photovoltaic function)	Byte0-1	setDcSandiaIrr/ getDcSandiaIrr	Set/query setting Photovoltaic Sandia mode Irr value	16	1	0	1	3000	1000		Set all ready states to be valid and switch to photovoltaic Sandia mode Set while active state only photovoltaic start state is valid FF 0-TF;1-SCMC;2-HEC
							Byte2	setDcSandiaTC/ getDcSandiaTC	Set/query setting Photovoltaic Sandia mode TC value	8	1	0	-40	85	25	°C	
							Byte3-4	setDcSandiaVmp/ getDcSandiaVmp	Set/query setting Photovoltaic Sandia mode Vmp value	16	0.01	0	0			V	
							Byte5-6	setDcSandiaPmp/ getDcSandiaPmp	Set/query setting Photovoltaic Sandia mode Pmp value	16	0.001	0	0			kW	
							Byte6	setDcSandiaFF/ getDcSandiaFF	Set/query setting Photovoltaic Sandia mode FF value	8							
21	6	F657	SA_PC/ SA_PC	0x18F657xx	Bi-directional	Set/Query Setting Photovoltaic Sandia Mode Parameters 2 (some models without photovoltaic function)	Byte0-1	setDcSandiaIrrRef/ getDcSandiaIrrRef	Set/query setting Photovoltaic Sandia mode IrrRef value	16	1	0	1	3000		Set all ready states to be valid and switch to photovoltaic Sas mode Set while active state only photovoltaic start state is valid	
							Byte2-3	setDcSandiaTRef/ getDcSandiaTRef	Set/query setting Photovoltaic Sandia mode Tref value	8	1	0	-40	85			°C
22	6	F658	SA_PC/ SA_PC	0x18F658xx	Bi-directional	Set/Query Setting Photovoltaic Parameters (some models without photovoltaic function)	Byte0	setDcSolarSearchMode/ getDcSolarSearchMode	Set/query setting Photovoltaic parameter operating mode	8	1	0	0	1			Set all ready states to be valid Operating mode 0-CV; 1-CC
							Byte1-2	setDcSolarFilter/ getDcSolarFilter	Set/query setting Photovoltaic parameter sampling filter	16	1	0	0	3125		Hz	
							Byte3	setDcSolarSpeed/ getDcSolarSpeed	Set/query setting Photovoltaic parameter control rate	8	1	0	1	200			
							Byte4	setDcSolarMargin/ getDcSolarMargin	Set/query setting Photovoltaic parameter setting margin	8	1	0	0	200		%	

23	6	F65A	SA_PC/ SA_PC	0x18F65Axx	Bi-directional	Set/Query Setting Photovoltaic SAS2 Mode Parameters (some models without photovoltaic function)	Byte0-1	setDcSas2Irr/ getDcSas2Irr	Set/query setting Photovoltaic Sas2 mode Irr value	16	1	0	1	3000	1000	Set all ready states to be valid and switch to photovoltaic Sas2 mode Set while active state only photovoltaic start state is valid	
							Byte2	setDcSas2TC/ getDcSas2TC	Set/query setting Photovoltaic Sas2 mode TC value	8	1	0	-40	85	25		°
							Byte3	setDcSas2FF/ getDcSas2FF	Set/query setting Photovoltaic Sas2 mode FF value	8	0.01	0	40	95	80		
							Byte4-5	setDcSas2Vmp/ getDcSas2Vmp	Set/query setting Photovoltaic Sas2 mode Vmp value	16	0.01	0	0				V
							Byte6-7	setDcSas2Pmp/ getDcSas2Pmp	Set/query setting Photovoltaic Sas2 mode Pmp value	16	0.001	0	0				kW
24	6	F660	SA_PC/ SA_PC	0x18F660xx	Bi-directional	Set/Query Setting Battery Simulation Parameters 1	Byte0	setDcBatSimBatType/ getDcBatSimBatType	Set/query setting Battery simulation battery type	8	1	0	1	3000		Set while ready state is valid and switch to battery simulation mode Battery mode: 0 Lithium Manganese Oxide LMO, 1 Lithium Cobalt Oxide LCO, 2 Lithium Iron Phosphate LFO, 3 Lithium Nickel Manganese Cobalt NCM, 4 Lithium Titanate LTO, 5 Lead-acid Pb, 6 Nickel-metal Hydride NiMH, 7 Nickel-cadmium NiCd, 8 Custom battery	
							Byte1-2	setDcBatSimVolMax/ getDcBatSimVolMax	Set/query setting Battery simulation battery voltage upper limit	16	0.01	0	0	8000			V
							Byte3-4	setDcBatSimVolStandard/ getDcBatSimVolStandard	Set/query setting Battery simulation battery standard voltage	16	0.01	0	0	8000			V
							Byte5-6	setDcBatSimVolMin/ getDcBatSimVolMin	Set/query setting Battery simulation battery voltage lower limit	16	0.01	0	0	8000			V
25	6	F661	SA_PC/ SA_PC	0x18F661xx	Bi-directional	Set/Query Setting Battery Simulation Parameters 2	Byte0-1	setDcBatSimCapacity/ getDcBatSimCapacity	Set/query setting Battery simulation battery capacity	16	0.1	0	1	3000		Set while ready state is valid and switch to battery simulation mode	
							Byte2-3	setDcBatSimResistance/ getDcBatSimResistance	Set/query setting Battery simulation battery internal resistance	16	0.001	0	1	500			Ω
							Byte4-5	setDcBatSimSerialCnt/ getDcBatSimSerialCnt	Set/query setting Battery simulation battery series number	16	1	0	1	9999			
							Byte6-7	setDcBatSimParallelCnt/ getDcBatSimParallelCnt	Set/query setting Battery simulation battery parallel number	16	1	0	1	9999			
26	6	F662	SA_PC/ SA_DC	0x18F662xx	Bi-directional	Set/Query Setting Battery Simulation Parameters 3	Byte0-1	setDcBatSimSocInitial/ getDcBatSimSocInitial	Set/query setting Battery simulation Soc initial	16	0.1	0	1	1000		Set while ready state is valid and switch to battery simulation mode SOC limit: 0 current limit 1 stop Curve display: 0 discharge 1 charge	
							Byte2-3	setDcBatSimChargeImax/ getDcBatSimChargeImax	Set/query setting Battery simulation charge Imax	16	0.01	0	0				A
							Byte4-5	setDcBatSimDischargeImax/ getDcBatSimDischargeImax	Set/query setting Battery simulation discharge Imax	16	0.01	0	0				A
							Byte6	setDcBatSimSocLimit/ getDcBatSimSocLimit	Set/query setting Battery simulation Soc limit	8		0	1				
							Byte7	setDcBatSimCurveShows/ getDcBatSimCurveShows	Set/query setting Battery simulation curve display	8		0	1				

27	6	F664	SA_PC	0x18F66406	Power Send	Generate Soc Curve Through Battery Limits	Byte0-1	setDcBatSimSocByVolMax	Generate Soc curve Battery voltage upper limit	16	0.01	0	0	8000	V	Set effective in ready mode and switch to battery simulation mode
							Byte2-3	setDcBatSimSocByVolVolStandard	Generate Soc curve Battery standard voltage	16	0.01	0	0	8000	V	
							Byte4-5	setDcBatSimSocByVolMin	Generate Soc curve Battery voltage lower limit	16	0.01	0	0	8000	V	
28	6	F666	SA_PC/ SA_PC	0x18F666xx	Bi-directional	Set/Query Setting Battery Simulation Soc Data 1	Byte0-1	setDcBatSimSoc0%/getDcBatSimSoc0%	Set/query setting Battery simulation Soc0%	16	0.01	0	0	8000	V	Set effective in ready mode and switch to battery simulation mode
							Byte2-3	setDcBatSimSoc10%/getDcBatSimSoc10%	Set/query setting Battery simulation Soc10%	16	0.01	0	0	8000	V	
							Byte4-5	setDcBatSimSoc20%/getDcBatSimSoc20%	Set/query setting Battery simulation Soc20%	16	0.01	0	0	8000	V	
							Byte6-7	setDcBatSimSoc30%/getDcBatSimSoc30%	Set/query setting Battery simulation Soc30%	16	0.01	0	0	8000	V	
29	6	F667	SA_PC/ SA_PC	0x18F667xx	Bi-directional	Set/Query Setting Battery Simulation Soc Data 2	Byte0-1	setDcBatSimSoc40%/getDcBatSimSoc40%	Set/query setting Battery simulation Soc40%	16	0.01	0	0	8000	V	Set effective in ready mode and switch to battery simulation mode
							Byte2-3	setDcBatSimSoc50%/getDcBatSimSoc50%	Set/query setting Battery simulation Soc50%	16	0.01	0	0	8000	V	
							Byte4-5	setDcBatSimSoc60%/getDcBatSimSoc60%	Set/query setting Battery simulation Soc60%	16	0.01	0	0	8000	V	
							Byte6-7	setDcBatSimSoc70%/getDcBatSimSoc70%	Set/query setting Battery simulation Soc70%	16	0.01	0	0	8000	V	
30	6	F668	SA_PC/ SA_PC	0x18F668xx	Bi-directional	Set/Query Setting Battery Simulation Soc Data 3	Byte0-1	setDcBatSimSoc80%/getDcBatSimSoc80%	Set/query setting Battery simulation Soc80%	16	0.01	0	0	8000	V	Set effective in ready mode and switch to battery simulation mode
							Byte2-3	setDcBatSimSoc90%/getDcBatSimSoc90%	Set/query setting Battery simulation Soc90%	16	0.01	0	0	8000	V	
							Byte4-5	setDcBatSimSoc100%/getDcBatSimSoc100%	Set/query setting Battery simulation Soc100%	16	0.01	0	0	8000	V	
31	6	F670	SA_PC/ SA_PC	0x18F670xx	Bi-directional	Set/Query Setting Charge and Discharge Parameters 1	Byte0	setDcChargeMode/getDcChargeMode	Set/query setting Charge and discharge working mode 0 discharge 1 charge	8	1	0	0	1	Set effective in ready mode and switch to charge-discharge mode Work mode 0 discharge 1 charge Battery protection OVP limit is 1.1 times the upper voltage limit	
							Byte1-2	setDcChargeBatOVP/getDcChargeBatOVP	Set/query setting Charge and discharge battery protection OVP	16	0.01	0	0			V
32	6	F671	SA_PC/ SA_PC	0x18F671xx	Bi-directional	Set/Query Setting Charge and Discharge Parameters 2	Byte0-1	setDcChargeU/ getDcChargeU	Set/query setting Charge and discharge charge voltage	16	0.01	0	0		V	Set effective in ready mode and switch to charge-discharge mode
							Byte2-3	setDcChargeI/ getDcChargeI	Set/query setting Charge and discharge charge current	16	0.01	0	0		A	
							Byte4-5	setDcChargeP/ getDcChargeP	Set/query setting Charge and discharge charge power	16	0.001	0	0		kW	
							Byte6-7	setDcChargeCutoffCur/ getDcChargeCutoffCur	Set/query setting Charge and discharge charge cut-off current	16	0.01	0	0		A	

33	6	F672	SA_PC/ SA_PC	0x18F672xx	Bi-directional	Set/Query Settings Charge and Discharge Parameters 3	Byte0	setDcChargeCutoffTime/ getDcChargeCutoffTime	Set/query setting Charge and discharge charge cut-off time switch	8	1	0	0	1		Set effective in ready mode and switch to charge-discharge mode
							Byte1	setDcChargeCutoffHour/ getDcChargeCutoffHour	Set/query setting Charge and discharge charge cut-off time hours	8	1	0	0	99	h	
							Byte2	setDcChargeCutoffMinute/ getDcChargeCutoffMinute	Set/query setting Charge and discharge charge cut-off time minutes	8	1	0	0	59	m	
							Byte3	setDcChargeCutoffSecond/ getDcChargeCutoffSecond	Set/query setting Charge and discharge charge cut-off time seconds	8	1	0	0	59	s	
							Byte4	setDcChargeCutoffAh/ getDcChargeCutoffAh	Set/query setting Charge and discharge charge cut-off Ah switch	8	1	0	0	1		
							Byte5-6	setDcChargeCutoffAhValue/ getDcChargeCutoffAhValue	Set/query setting Charge and discharge charge cut-off Ah value	16	0.1	0	0	3000	Ah	
34	6	F673	SA_PC/ SA_PC	0x18F673xx	Bi-directional	Set/Query Settings Charge and Discharge Parameters 4	Byte0-1	setDcDisDischargeI/ getDcDischargeI	Set/query setting Charge and discharge current	16	0.01	0	0		A	Set effective in ready mode and switch to charge-discharge mode
							Byte2-3	setDcDischargeP/ getDcDischargeP	Set/query setting Charge and discharge power	16	0.001	0	0		kW	
							Byte4-5	setDcDischargeCutoffVol/ getDcDischargeCutoffVol	Set/query setting Charge and discharge cut-off voltage	16	0.01	0	0		V	
35	6	F674	SA_PC/ SA_PC	0x18F674xx	Bi-directional	Set/Query Settings Charge and Discharge Parameters 5	Byte0	setDcDischargeCutoffTime/ getDcDischargeCutoffTime	Set/query setting Charge and discharge cut-off time switch	8	1	0	0	1		Set effective in ready mode and switch to charge-discharge mode
							Byte1	setDcDischargeCutoffHour/ getDcDischargeCutoffHour	Set/query setting Charge and discharge cut-off time hours	8	1	0	0	99	h	
							Byte2	setDcDischargeCutoffMinute/ getDcDischargeCutoffMinute	Set/query setting Charge and discharge cut-off time minutes	8	1	0	0	59	m	
							Byte3	setDcDischargeCutoffSecond/ getDcDischargeCutoffSecond	Setting/Query Setting Discharge Cut-off Time Seconds	8	1	0	0	59	s	
							Byte4	setDcDischargeCutoffAh/ getDcDischargeCutoffAh	Setting/Query Setting Discharge Cut-off Ah Switch	8	1	0	0	1		
							Byte5-6	setDcDischargeCutoffAhValue/ getDcDischargeCutoffAhValue	Setting/Query Setting Discharge Cut-off Ah Value	16	0.1	0	0	3000	Ah	
36	6	F680	SA_PC/ SA_DC	0x18F680xx	Bi-directional	Set/Query Settings Load Working Mode Voltage, Current, Power	Byte0	setDcLoadMode/ getDcLoadMode	Setting/Query Setting Load Working Mode	8	1	0	0		Ω	All ready states are valid during setting and switch to load mode. During output state, only load state is valid and can be adjusted online (online adjustment for work mode is invalid). Work modes: 0CC, 1CV, 2CP, 3CR, 4CVCC, 5CVCR, 6CCCR, 7AUTO.
							Byte1-2	setDcLoadLoad/ getDcLoadLoad	Setting/Query Setting Load Mode Voltage	16	0.01	0	0		V	
							Byte3-4	setDcLoadCur/ getDcLoadCur	Setting/Query Setting Load Mode Current	16	0.01	0	0		A	
							Byte5-6	setDcLoadPow/ getDcLoadPow	Setting/Query Setting Load Mode Power	16	0.001	0	0		kW	
37	6	F681	SA_PC/ SA_DC	0x18F681xx	Bi-directional	Set/Query Settings Load Mode Resistance	Byte0-2	setDcLoadRes/ getDcLoadRes	Setting/Query Setting Load Mode Resistance	24	0.01	0	1		Ω	All ready states are valid during setting and switch to load mode. During output state, only load state is valid and can be adjusted online.

Command Example of CAN

Message Command	Command direction	ID Example of power receiving 06 (remote address set to 6) Example of power sending 0D (power address set to 13)	Data Format: Inter	Description
Stop Power Output	Power Receive	0x18F61006	00 00 00 00 00 00 00 00	
Start Power Output	Power Receive	0x18F61006	FF 00 00 00 00 00 00 00	
Power Sampling Return	Power Send	0x18F6200D	02 F4 01 E8 18 FC FF	Return to CV output on, output sampling value 50V-10A
Power Status Return	Power Send	0x18F6210D	10 00 00 00 00 00 00 00	Return to normal ready mode
Close Auto Return	Power Receive	0x18F61206	00 00 00 00 00 00 00 00	Power will be set to ON on each boot, closing here will not save the state
Open Auto Return	Power Receive	0x18F61206	01 01 00 00 00 00 00 00	
Set Power Mode	Power Receive	0x18F61106	10 00 00 00 00 00 00 00	
Set Power Voltage Current Power	Power Receive	0x18F63006	88 13 D0 07 B8 0B	Set to 50V20A3kw
Query Power Settings Parameters	Power Receive	0x18F61806	30 F6 00 00 00 00 00 00	
Query Power Settings Return	Power Send	0x18F6300D	88 13 D0 07 B8 0B	Query setting returns 50V20A3kw
Set Power Bidirectional Parameter Mode	Power Receive	0x18F61106	12 00 00 00 00 00 00 00	
Set Power Bidirectional Parameter 1 Voltage Positive/Negative Current	Power Receive	0x18F63206	88 13 D0 07 B8 0B	Set to 50V+20A-30A
Set Power Bidirectional Parameter 2 Positive/Negative Power	Power Receive	0x18F63306	D0 07 B8 0B	Set to +2kw-3kw
Query Power Bidirectional Parameter 1 Settings	Power Receive	0x18F61806	32 F6 00 00 00 00 00 00	
Query Power Bidirectional Parameter 1 Settings Return	Power Send	0x18F6320D	88 13 D0 07 B8 0B	Query setting returns 50V20A3kw
Set Load Mode	Power Receive	0x18F61106	60 00 00 00 00 00 00 00	
Set Load Parameter 1	Power Receive	0x18F68006	07 C8 00 D0 07 B8 0B	Set to Auto 20.0V 20.00A 3.000kw
Set Load Parameter 2	Power Receive	0x18F68106	88 13 00	Set to 50.00 ohms
Query Load Settings Parameter 1	Power Receive	0x18F61806	80 F6 00 00 00 00 00 00	
Query Load Settings Parameter 1 Return	Power Send	0x18F6800D	07 C8 00 D0 07 B8 0B	Query setting returns Auto 20.0V 20.00A 3.000kw
Query Load Settings Parameter 2	Power Receive	0x18F61806	81 F6 00 00 00 00 00 00	
Query Load Settings Parameter 2 Return	Power Send	0x18F6800D	88 13 00	Set to 50.00 ohms
Set Sequence Mode	Power Receive	0x18F61106	20 01 00 00 00 00 00 00	Set serial number to 1
Set Sequence Parameter 1	Power Receive	0x18F64006	01 05 00 00 03 00 00 00	Set sequence 1 step 5: work mode VIP and time 3 minutes
Set Sequence Parameter 2	Power Receive	0x18F64106	01 05 88 13 D0 07 B8 0B	Set sequence 1 step 5: Para1 50V Para2 20A and Para3 3kVA
Set Sequence Parameter 3	Power Receive	0x18F64206	01 05 01 00 00 00 00 00	Set sequence 1 step 5: step enable, no loop, next step
Query Sequence Parameter 1	Power Receive	0x18F61806	40 F6 01 05 00 00 00 00	Query sequence 1 step 5 parameter 3
Query Sequence Parameter 1 Return	Power Send	0x18F6400D	01 05 00 00 03 00 00 00	Query setting sequence 1 step 5 returns: time 3 minutes
Set Photovoltaic SAS Mode	Power Receive	0x18F61106	30 00 00 00 00 00 00 00	
Set Photovoltaic SAS Parameters	Power Receive	0x18F65206	88 13 A0 0F D0 07 40 06	Set Voc50V Vmp40V Isc20A Imp16A
Query Photovoltaic SAS Parameters	Power Receive	0x18F61806	52 F6 00 00 00 00 00 00	
Query Photovoltaic SAS Parameters Return	Power Send	0x18F6520D	88 13 A0 0F D0 07 40 06	Query setting returns Voc50V Vmp40V Isc20A Imp16A
Set Photovoltaic EN50530 Mode	Power Receive	0x18F61106	31 00 00 00 00 00 00 00	
Set Photovoltaic EN50530 Parameters	Power Receive	0x18F65406	E8 03 A0 0F D0 07 01	Set Irr1000 Vmp40V Vmp2kw TF
Query Photovoltaic EN50530 Parameters	Power Receive	0x18F61806	54 F6 00 00 00 00 00 00	
Query Photovoltaic EN50530 Parameters Return	Power Send	0x18F6540D	E8 03 A0 0F D0 07 01	Query setting returns Irr1000 Vmp40V Vmp2kw TF
Set Photovoltaic Sandia Mode	Power Receive	0x18F61106	32 00 00 00 00 00 00 00	
Set Photovoltaic Sandia Parameters	Power Receive	0x18F65606	E8 03 19 A0 0F D0 07 02	Set Irr1000 25° Vmp40V Vmp2kw HEC
Query Photovoltaic Sandia Parameters	Power Receive	0x18F61806	56 F6 00 00 00 00 00 00	
Query Photovoltaic Sandia Parameters Return	Power Send	0x18F6560D	E8 03 19 A0 0F D0 07 02	Query setting returns Irr1000 25° Vmp40V Vmp2kw HEC
Set Photovoltaic Parameters	Power Receive	0x18F65806	01 E8 03 02 05	Set CC mode, filter 1000Hz, output rate 2, margin 5%
Query Photovoltaic Settings Parameters	Power Receive	0x18F61806	58 F6 00 00 00 00 00 00	
Query Photovoltaic Settings Return	Power Send	0x18F6580D	01 E8 03 02 05	Query setting returns CC mode, filter 1000Hz, output rate 2, margin 5%
Set Photovoltaic Sas2 Mode	Power Receive	0x18F61106	34 00 00 00 00 00 00 00	
Set Photovoltaic Sas2 Parameters	Power Receive	0x18F65A06	E8 03 19 50 A0 0F D0 07	Set Irr1000 25° FF0.8 Vmp40V Vmp2kw
Query Photovoltaic Sas2 Parameters	Power Receive	0x18F61806	5A F6 00 00 00 00 00 00	
Query Photovoltaic Sas2 Parameters Return	Power Send	0x18F65A0D	E8 03 19 50 A0 0F D0 07	Query setting returns Irr1000 25° FF0.8 Vmp40V Vmp2kw
Set Battery Simulation Mode	Power Receive	0x18F61106	40 00 00 00 00 00 00 00	
Set Battery Simulation Parameter 1	Power Receive	0x18F66006	08 9A 01 7C 01 40 01	Custom, 4.1V 3.8V 3.2V
Set Battery Simulation Parameter 2	Power Receive	0x18F66106	64 00 05 00 14 00 0A 00	10Ah, 0.005 ohms, series 20, parallel 10
Set Battery Simulation Parameter 3	Power Receive	0x18F66206	F4 01 E8 03 D0 07 01 01	Initial 50%, charge 10A, discharge 20A, stop, charge
Query Battery Simulation Parameter 1	Power Receive	0x18F61806	60 F6 00 00 00 00 00 00	
Set Battery Simulation SOC Generation	Power Receive	0x18F66406	9A 01 7C 01 40 01	Generate with 4.1V 3.8V 3.2V

Set Battery Simulation SOC Parameter 1	Power Receive	0x18F66606	4E 01 70 01 78 01 7C 01	3.34V 3.68V 3.76V 3.80V
Set Battery Simulation SOC Parameter 2	Power Receive	0x18F66706	7F 01 82 01 85 01 88 01	3.83V 3.86V 3.89V 3.92V
Set Battery Simulation SOC Parameter 3	Power Receive	0x18F66806	8B 01 8F 01 97 01	3.95V 3.99V 4.07V
Query Battery Simulation SOC Parameter 1	Power Receive	0x18F61806	66 F6 00 00 00 00 00 00	
Set Charge/Discharge Mode	Power Receive	0x18F61106	50 00 00 00 00 00 00 00	
Set Charge/Discharge Parameters	Power Receive	0x18F67006	01 DC 05	Charging OVP150V
Set Charge/Discharge Parameters	Power Receive	0x18F67106	B0 04 E8 03 88 13 1E 00	Charging voltage 120V current 10A power 5kw cut-off current 0.3A
Set Charge/Discharge Parameters	Power Receive	0x18F67206	01 01 1E 00 01 64 00	Charging cut-off time open 1 hour 30 minutes, cut-off capacity open 10A
Set Charge/Discharge Parameters	Power Receive	0x18F67306	E8 03 88 13 64 00	Discharge current 10A power 5kw cut-off voltage 10V
Set Charge/Discharge Parameters	Power Receive	0x18F67406	01 01 1E 00 01 64 00	Charging cut-off time open 1 hour 30 minutes, cut-off capacity open 10A
Query Charge/Discharge Parameters	Power Receive	0x18F61806	70 F6 00 00 00 00 00 00	

SCPI and command description



Note

- Photovoltaic related content is only valid when the photovoltaic function is enabled.
- After the photovoltaic startup and online adjustment command is executed, there will be tens of ms unable to respond to the communication command due to the need to calculate the photovoltaic curve.

SCPI Communication Protocol	173
Common Symbols	173
Data Format	173
Basic Definitions	173
SCPI Communication List	175
Common Commands	179
Instrument Commands FETCH/MEASURE System	181
OUTPUT System	183
SOURCE System	186
BISOURCE System	188
LOAD System	190
LIST System	192
SAS System (For some models only)	198
EN System (For some models only)	200
SANDIA System (For some models only)	202
SOLAR System (For some models only)	205
BASIMULAR System	207
CHARGE System	212
Supplementary Description of the communication protocol	220

PC Control Software.....	221
Introduction to host computer control software.....	221
Installation Description of the PC control software	223
Connecting the PC control software	224

SCPI Communication Protocol

Common Symbols

Angle bracket < > parameter abbreviations in Angle brackets (see below table)

Separator | Specifies the parameter of either partition

Square brackets [] Square brackets are optional. For example, OUTP[:STATe] indicates that STATe can be omitted.

Braces {} Braces indicate that the parameter can be repeated. <a>{} indicates that parameter A must be entered, while parameter B can be omitted or entered one or more times.

Data Format

All data formats, including send and Return data, are ASCII. The data can be numbers or strings

Symbol	Description	Example
<NR1>	Integer (without decimal point)	123
<NR2>	A number with a decimal place	12.3
<NR3>	Numbers with decimals and exponents	1.23E+2
<Boolean>	Boolean parameter, only ON OFF	ON OFF
<CRD>	The value is in bytes format. The maximum number of bytes is 12	
<SRD>	String format	

Basic Definitions

Instruction tree:

Native instructions are based on a hierarchical structure, also known as a tree system. Instructions on all tree nodes must be written.

Program header:

The program header is the key that identifies the instruction. The machine accepts both upper and lower case letters. It is divided into common instruction table head and instrument control table head.

Common command and query header:

The syntax and query header of common instructions are described in detail in IEEE488.2. When an instruction preceded by "*" is a common instruction.

Instrument control head:

The instrument controls the watch head, and each watch head has two formats: long and short. The short format of the table header is represented by uppercase letters, and the rest of the table header is represented by lowercase letters.

Separator symbol:

When an instruction has more than one header, it needs to be separated by a colon (:).

The header and parameter data need to be separated by a space ().

Multiple instructions in the same instruction, need to use semicolon (;) To separate.

End character (<PMT>) There are three types:

- (1) <END> : End or Confirmation (EOI)
- (2) <NL> : ASCII character 0x0A (hexadecimal 10)
- (3) <NL><END>: End or confirm (EOI) plus 0x0A

SCPI Communication List

Common Commands	179
*CLS	179
*ESR?	179
*IDN?	180
*RST	180
Instrument Commands FETCH/MEASURE System	181
FETCh/ MEASure:ALL	181
FETCh/ MEASure:CURRent	181
FETCh/ MEASure:POWer	181
FETCh/ MEASure:VOLTagE	182
FETCh/ MEASure:MPPEfficiency	182
OUTPUT System	183
OUTPut	183
OUTPut:STATe	183
OUTPut:RISE	184
OUTPut:MODE	184
OUTPut:PROTection	184
OUTPut:PROTection:CLear	185
SOURCE System	186
SOURce:ALL	186
[SOURce:]CURRent	186
[SOURce:]POWer	186
[SOURce:]VOLTagE	187
BISOURCE System	188
BISOURce:NCURRent	188
BISOURce:NPOWer	188
BISOURce:PCURRent	189
BISOURce:PPOWer	189
BISOURce:]VOLTagE	189
LOAD System	190
LOAD:ALL	190
LOAD:CURRent	190
LOAD:POWer	190
LOAD:RESistance	191
LIST System	192
LIST:SEQuence	192
LIST:STEP	193

LIST:ALL	193
LIST:MODE	193
LIST:PAR1	193
LIST:PAR2	194
LIST:PAR3	194
LIST:TIME	194
LIST:ENABle	195
LIST:LOOP	195
LIST:COUNTloop	195
LIST:OPERation	195
LIST:JUMP	196
LIST:OUTPut	196
LIST:OUTPut:SEQuence	196
LIST:OUTPut:STEP	197
LIST:OUTPut:COUNTloop	197
LIST:OUTPut:TIME	197
SAS System (For some models only)	198
SAS:ALL	198
SAS:VOC	198
SAS:VMP	198
SAS:ISC	199
SAS:IMP	199
EN System (For some models only)	200
EN:ALL	200
EN:IRR	200
EN:VMP	200
EN:PMP	201
EM:FF	201
SANDIA System (For some models only)	202
SANDia:ALL	202
SANDia:IRR	202
SANDia:IRRRef	202
SANDia:TC	203
SANDia:TREF	203
SANDia:VMP	203
SANDia:PMP	203
SANDia:FF	204
SOLAR System (For some models only)	205
SOLAr:FILTer	205
SOLAr:MARgin	205

SOLAR:MODE	205
SOLAR:SPEEd	206
BASIMULAR System.....	207
BASIMular:BATtery:BASImular:S100.....	207
BASIMular:CAPAcity	208
BASIMular:RESistance.....	208
BASIMular:VMax.....	208
BASIMular:VSt	208
BASIMular:VMin	209
BASIMular:SERial.....	209
BASIMular:PARAllel	209
BASIMular:SINtial	209
BASIMular:ICHArge.....	210
BASIMular:IDISChArge.....	210
BASIMular:SLIMit	210
BASIMular:CSHOW.....	211
BASIMular:S0~S100.....	211
CHARGE System	212
CHARge:MODE	212
CHARge:OVP	213
CHARge:UCHArge.....	213
CHARge:ICHArge	213
CHARge:PCHArge	213
CHARge:COCUrrent	214
CHARge:COTSwitch	214
CHARge:COTHour	214
CHARge:COTMinute	214
CHARge:COTSecond	215
CHARge:COASwitch	215
CHARge:COAAh	215
CHARge:IDISChArge	215
CHARge:PDISChArge	216
CHARge:DOVoltage.....	216
CHARge:DOTSwitch.....	216
CHARge:DOTHour	217
CHARge:DOTMinute.....	217
CHARge:DOTSecond.....	217
CHARge:DOASwitch.....	217
CHARge:DOAAh	218
SYSTEM Subsystem	219
SYSTem:ERRor	219

SYSTem:VERSion219

Common Commands

*CLS	179
*ESR?	179
*IDN?	180
*RST	180

*CLS

Set →

Description Clear status, This instruction clears the following registers "Questionable Status Event"

Syntax *CLS

*ESR?

→ Query

Description Query read. Standard Event Status Event registers *

Query syntax *ESR?

*

Bit	Name	Description
0	OPC	Operation complete
1	-----	
2	QYE	Query error
3	DDE	Device dependent error
4	EXE	Execution Error
5	CME	Command Instruction Error
6	-----	
7	PON	Power On

***IDN?**

→ **Query**

Description	Query company name, machine model, master version number, display version number		
Query syntax	*IDN?		
	GW	Company name	V1.00c Control Version no.
	RBS	Model no.	V1.00d Display Version no.

***RST**

Description	Restores the power supply to the initial state.
Syntax	*RST

Instrument Commands

FETCH/MEASURE System

FETCH/ MEASure:ALL	181
FETCH/ MEASure:CURRent.....	181
FETCH/ MEASure:POWer.....	181
FETCH/ MEASure:VOLTage	182
FETCH/ MEASure:MPPEfficiency	182

FETCH/ MEASure:ALL → Query

Description	Query measure of voltage, current, power
Query Syntax	FETCH:ALL? MEASure:ALL?
Query return parameters	Return in the format of voltage, current, and power.

FETCH/ MEASure:CURRent → Query

Description	Query measure of current, unit is A.
Query Syntax	FETCH:CURRent? MEASure:CURRent?
Query return parameters	<NR2>

FETCH/ MEASure:POWer → Query

Description	Query measure of power , unit is kW
Query Syntax	FETCH:POWer? MEASure:POWer?
Query return parameters	<NR2>

FETCh/ MEASure:VOLTage

→ **Query**

Description	Query measure of voltage , unit is V.
Query Syntax	FETCh:VOLTage? MEASure:VOLTage?
Query return parameters	<NR2>

FETCh/ MEASure:MPPEfficiency

→ **Query**

Description	Query Mpp instantaneous efficiency, unit is %.
Query Syntax	FETCh:MPPEfficiency? MEASure:MPPEfficiency?
Query return parameters	<NR2>

OUTPUT System

OUTPut	183
OUTPut:STATe	183
OUTPut:RISE	184
OUTPut:MODE.....	184
OUTPut:PROTection	184
OUTPut:PROTection:CLEar.....	185

OUTPut

→ Query

Description	Query whether power is started or stop	
Query Syntax	OUTPut OFF ON OUTPut?	
Query return parameters	ON	Power is on
	OFF	Power is off

OUTPut:STATe

→ Query

Description	Query state	
Query Syntax	:OUTPut:STATe?	
Query return parameters	OFF	
	CV	
	CC	
	CP	
	PV	
	CR	

Set →

→ Query

OUTPut:RISE

Description Set or query SoftRise. Its unit is second.

Syntax OUTPut:RISE<NR2>

Query Syntax OUTPut:RISE?

Parameter/
Return Parameter <NR2>

Set →

→ Query

OUTPut:MODE

Description Set or query mode.

Syntax OUTPut:MODE

Query Syntax OUTPut:MODE?

Parameter/
Return Parameter NORMAL | LIST | SAS | EN | SANDIA | BISOURCE
| LOAD | BATSIM | CHARGE | DISCHARGE | ALA
RM | OTHER,READY | RUN | PAUSE | RUNEND

OUTPut:PROTection

→ Query

Description Set or query Alarm.

Query Syntax OUTPut:PROTection?

Query return parameters NONE | ALARM | TIP,MZ | OVP | OT | TERMINAL
| OV | LV | OC | LC | OTHER,<NR1>

Symbol	NONE	ALARM	TIP	MZ	OVP	OT
Description	No alarm	Alarm	Alarm tip: Non-stop output	Module Error	Over voltage	Over hot
TERMINAL	OV	LV	OC	LC	OTHER	<NR1>
Reverse connect	Over voltage	Under voltage	Over current	Under current	Other error	Alarm Code

OUTPut:PROTEction:CLEar

Description	Clear alarm status (Note: alarm abnormal fault need to be eliminated)
-------------	---

Syntax	None
--------	------

Parameter/ Return Parameter	None
--------------------------------	------

SOURCE System

SOURce:ALL	186
[SOURce:]CURRent.....	186
[SOURce:]POWer.....	186
[SOURce:]VOLTage	187

SOURce:ALL

→ Query

Description	Query setting of voltage, current, power in source mode.
Query Syntax	:SOURce:ALL?
Query return parameters	Return in the format of voltage, current, and power

Set →

[SOURce:]CURRent

→ Query

Description	Set or query current in source mode, unit is A.
Syntax	[SOURce:]CURRent<NR2>
Query Syntax	[SOURce:]CURRent?
Parameter/ Return Parameter	<NR2>

Set →

[SOURce:]POWer

→ Query

Description	Set or query power in source mode, unit is kW
Syntax	[SOURce:]POWer<NR2>
Query Syntax	[SOURce:]POWer?
Parameter/ Return Parameter	<NR2>

[SOURce:]VOLTage



Description	Set or query voltage in source mode, unit is V
Syntax	[SOURce:]VOLTage<NR2>
Query Syntax	[SOURce:]VOLTage?
Parameter/ Return Parameter	<NR2>

BISOURCE System

BISOURce:NCURRent	188
BISOURce:NPOWer	188
BISOURce:PCURRent.....	189
BISOURce:PPOWer	189
BISOURce:JVOLTage.....	189

BISOURce:ALL

→ Query

Description Query setting of source bidirectional parameters mode voltage, positive current, positive power, negative current, negative power

Query Syntax :BISOURce:ALL?

Query return parameters Return in the format of voltage, positive current, positive power , negative current, and negative power

Set →

BISOURce:NCURRent

→ Query

Description Set or query current in source bidirectional parameters mode. Unit is A.

Syntax BISOURce:NCURRent<NR2>

Query Syntax BISOURce:NCURRent?

**Parameter/
Return Parameter** <NR2>

Set →

BISOURce:NPOWer

→ Query

Description Set or query negative power in source bidirectional parameters mode. Unit is kW

Syntax BISOURce:NPOWer<NR2>

Query Syntax BISOURce:NPOWer?

Parameter/ Return Parameter <NR2>

BISOURce:PCURRent

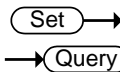

Description Set or query positive current in source bidirectional parameters mode. Unit is A

Syntax BISOURce:PCURRent<NR2>
Query Syntax BISOURce:PCURRent?

Parameter/ Return Parameter <NR2>

BISOURce:PPOWer

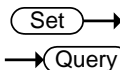

Description Set or query positive power in source bidirectional parameters mode. Unit is kW

Syntax BISOURce:PPOWer<NR2>
Query Syntax BISOURce:PPOWer?

Parameter/ Return Parameter <NR2>

BISOURce:]VOLTage

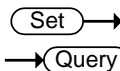

Description Set or query voltage in source bidirectional parameters mode. Unit is V

Syntax BISOURce:]VOLTage<NR2>
Query Syntax BISOURce:]VOLTage?

Parameter/ Return Parameter <NR2>

LOAD System

LOAD:ALL	190
LOAD:CURRent	190
LOAD:POWer	190
LOAD:RESistance	191

LOAD:ALL

→ Query

Description	Query setting of load mode resistance, current, power
Query Syntax	LOAD:ALL?
Query return parameters	Return in the format of resistance, current, and power.

Set →

LOAD:CURRent

→ Query

Description	Set or query current in load mode. Unit is A
Syntax	LOAD:CURRent<NR2>
Query Syntax	LOAD:CURRent?
Parameter/ Return Parameter	<NR2>

Set →

LOAD:POWer

→ Query

Description	Set or query power in load mode. Unit is kW
Syntax	LOAD:POWer?<NR2>
Query Syntax	LOAD:POWer?
Parameter/ Return Parameter	<NR2>

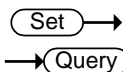

LOAD:RESistance

Description	Set or query voltage in load mode, unit is Ω
Syntax	LOAD:RESistance<NR2>
Query Syntax	LOAD:RESistance?
Parameter/ Return Parameter	<NR2>

LIST System*

LIST:SEquence	192
LIST:STEP	193
LIST:ALL.....	193
LIST:MODE.....	193
LIST:PAR1	193
LIST:PAR2	194
LIST:PAR3	194
LIST:TIME	194
LIST:ENABle	195
LIST:LOOP.....	195
LIST:COUNtloop	195
LIST:OPERation	195
LIST:JUMP	196
LIST:OUTPut	196
LIST:OUTPut:SEquence	196
LIST:OUTPut:STEP.....	197
LIST:OUTPut:COUNtloop.....	197
LIST:OUTPut:TIME.....	197



Note

When operating List Mode via Remote Control, any List Mode command sent will automatically save the corresponding parameters upon execution. No additional Save command is required.

This behavior differs from manual operation, where the user must press the [Save] key to store the configured parameters.

LIST:SEquence

Set →

→ Query

Description	Set or query list sequence.
-------------	-----------------------------

Syntax	LIST:SEquence<NR1>
--------	--------------------

Query Syntax	LIST:SEquence?
--------------	----------------

Parameter/ Return Parameter	<NR1>
--------------------------------	-------

LIST:STEP

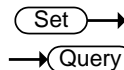

Description	Set or query list step.
Syntax	LIST:STEP<NR1>
Query Syntax	LIST:STEP?
Parameter/ Return Parameter	<NR1>

LIST:ALL



Description	Query all step parameters.
Query Syntax	LIST:ALL?
Query return parameters	Return in the format of sequence, step, mode, parameter1-3, time, enable, loop set, loop count, operation, jump list.

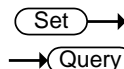

LIST:MODE

Description	Set or query mode
Syntax	LIST:MODE{UIP URAMP IRAMP}
Query Syntax	LIST:MODE?
Parameter/ Return Parameter	UIP
	URAMP
	IRAMP

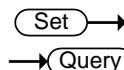

LIST:PAR1

Description	Set or query parameter 1, See table 3-6-2 for details
-------------	---

Syntax LIST:PAR1<NR2>

Query Syntax LIST:PAR1?

Parameter/
Return Parameter <NR2>

Set →

LIST:PAR2

→ Query

Description Set or query parameter 2. See table 3-6-2 for details

Syntax LIST:PAR2<NR2>

Query Syntax LIST:PAR2<NR2>?

Parameter/
Return Parameter <NR2>

Set →

LIST:PAR3

→ Query

Description Set or query parameter 3, See table 3-6-2 for details

Syntax LIST:PAR3<NR2>

Query Syntax LIST:PAR3?

Parameter/
Return Parameter <NR2>

Set →

LIST:TIME

→ Query

Description Set or query time, unit is second. See table 3-6-2 for details

Syntax LIST:TIME<NR2>

Query Syntax LIST:TIME?

Parameter/
Return Parameter <NR2>

LIST:ENABLE



Description	Set or query enable step
Syntax	LIST:ENABLE{OFF ON PAUSE}
Query Syntax	LIST:ENABLE?
Parameter/ Return Parameter	OFF
	ON
	PAUSE

LIST:LOOP



Description	Set or query Loop set
Syntax	LIST:LOOP {OFF BEGIN END}
Query Syntax	LIST:LOOP?
Parameter/ Return Parameter	OFF
	BEGIN
	END

LIST:COUNTloop



Description	Set or query Loop count.
Syntax	LIST:COUNTloop <NR1>
Query Syntax	LIST:COUNTloop?
Parameter/ Return Parameter	<NR1>

LIST:OPERation



Description	Set or query operation.
Syntax	LIST:OPERation{NEXT STOP JUMP}
Query Syntax	LIST:OPERation?

Parameter/ Return Parameter	NEXT	
	STOP	
	JUMP	

LIST:JUMP

Set →

→ Query

Description	Set or query jump sequences	
Syntax	LIST:JUMP <NR1>	
Query Syntax	LIST:JUMP?	
Parameter/ Return Parameter	<NR1>	

Set →

→ Query

LIST:OUTPut

Description	Set or query list output.	
Syntax	LIST:OUTPut{OFF ON SINGLE PAUSE CONTINUE}	
Query Syntax	LIST:OUTPut?	
Parameter/ Return Parameter	OFF	
	ON	
	SINGLE	
	PAUSE	
	CONTINUE	

LIST:OUTPut:SEquence

→ Query

Description	Query present list running sequence.	
Query Syntax	LIST:OUTPut:SEquence<NR1>?	
Parameter/ Return Parameter	<NR1>	

LIST:OUTPut:STEP

→ Query

Description	Query present list running step.
-------------	----------------------------------

Query Syntax	LIST:OUTPut:STEP<NR1>?
--------------	------------------------

Parameter/ Return Parameter	<NR1>
--------------------------------	-------

LIST:OUTPut:COUNTloop

→ Query

Description	Query present list running loop.
-------------	----------------------------------

Query Syntax	LIST:OUTPut:COUNTloop<NR1>?
--------------	-----------------------------

Query return parameters	<NR1>
----------------------------	-------

LIST:OUTPut:TIME

→ Query

Description	Query present list running remain time. Unit is s
-------------	---

Query Syntax	LIST:OUTPut:TIME<NR2>?
--------------	------------------------

Query return parameters	<NR2>
----------------------------	-------

SAS System (For some models only)

SAS:ALL.....	198
SAS:VOC	198
SAS:VMP	198
SAS:ISC	199
SAS:IMP	199

SAS:ALL

→ Query

Description	Query Voc, Vmp, Isc, Imp
Query Syntax	SAS:ALL?
Query return parameters	Return in the format of Voc, Vmp, Isc, Imp

Set →

SAS:VOC

→ Query

Description	Set or query Voc, unit is V
Syntax	SAS:VOC<NR2>
Query Syntax	SAS:VOC?
Parameter/ Return Parameter	<NR2>

Set →

SAS:VMP

→ Query

Description	Set or query Vmp, unit is V
Syntax	SAS:VMP<NR2>
Query Syntax	SAS:VMP?
Parameter/ Return Parameter	<NR2>

SAS:ISC

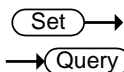

Description	Set or query Isc, unit is A
Syntax	SAS:ISC<NR2>
Query Syntax	SAS:ISC?
Parameter/ Return Parameter	<NR2>

SAS:IMP

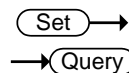

Description	Set or query Imp, unit is A.
Syntax	SAS:IMP<NR2>
Query Syntax	SAS:IMP?
Parameter/ Return Parameter	<NR2>

EN System (For some models only)

EN:ALL	200
EN:IRR	200
EN:VMP	200
EN:PMP	201
EM:FF	201

EN:ALL

→ Query

Description	Query Irr, Vmp, Pmp, FF
Query Syntax	EN:ALL?
Query return parameters	Return in the format of Irr, Vmp, Pmp, FF

Set →

EN:IRR

→ Query

Description	Set or query Irr, unit is W/m ²
Syntax	EN:IRR<NR2>
Query Syntax	EN:IRR?
Parameter/ Return Parameter	<NR2>

Set →

EN:VMP

→ Query

Description	Set or query Vmp, unit is V
Syntax	EN:VMP<NR2>
Query Syntax	EN:VMP?
Parameter/ Return Parameter	<NR2>

EN:PMP



Description	Set or query Pmp. Unit is kW
Syntax	EN:PMP<NR2>
Query Syntax	EN:PMP?
Parameter/ Return Parameter	<NR2>

EM:FF



Description	Set or query FF.
Syntax	EM:FF{cSi TF}
Query Syntax	EM:FF?
Parameter/ Return Parameter	cSi TF

SANDIA System (For some models only)

SANDia:ALL	202
SANDia:IRR	202
SANDia:IRRRef	202
SANDia:TC.....	203
SANDia:TREF.....	203
SANDia:VMP	203
SANDia:PMP	203
SANDia:FF	204

SANDia:ALL

→ Query

Description	Query Irr, IrrRef, Tc, TRef, Vmp, Pmp,FF
Query Syntax	SANDia:ALL?
Query return parameters	Return in the format of Irr, IrrRef, Tc, TRef, Vmp, Pmp, FF

Set →

SANDia:IRR

→ Query

Description	Set or query Irr, unit is W/m ²
Syntax	SANDia:IRR<NR1>
Query Syntax	SANDia:IRR?
Parameter/ Return Parameter	<NR1>

Set →

SANDia:IRRRef

→ Query

Description	Set or query IrrRef, unit is W/m ²
Syntax	SANDia:IRRRef <NR1>
Query Syntax	SANDia:IRRRef?
Parameter/ Return Parameter	<NR1>

SANDia:TC

Set →
→ Query

Description Set or query Tc, unit is °C.

Syntax SANDia:TC<NR1>

Query Syntax SANDia:TC?

Parameter/
Return Parameter <NR1>

SANDia:TREF

Set →
→ Query

Description Set or query TRef, unit is °C.

Syntax SANDia:TREF<NR1>

Query Syntax SANDia:TREF?

Parameter/
Return Parameter <NR1>

SANDia:VMP

Set →
→ Query

Description Set or query Vmp, unit is kW

Syntax SANDia:VMP<NR2>

Query Syntax SANDia:VMP?

Parameter/
Return Parameter <NR2>

SANDia:PMP

Set →
→ Query

Description Set or query Pmp, unit is kW

Syntax SANDia:PMP<NR2>

Query Syntax SANDia:PMP?

Parameter/
Return Parameter <NR2>

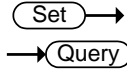
**SANDia:FF**

Description	Set or query FF.
Syntax	SANDia:FF{TF SCMC HEC}
Query Syntax	SANDia:FF?
Parameter/ Return Parameter	TF
	SCMC
	HEC

SOLAR System (For some models only)

SOLAr:FILTer	205
SOLAr:MARgin	205
SOLAr:MODE	205
SOLAr:SPEEd	206

SOLAr:FILTer (Set) → → (Query)

Description	Set or query solar filter, unit is Hz.
Syntax	SOLAr:FILTer<NR1>
Query Syntax	SOLAr:FILTer?
Parameter/ Return Parameter	<NR1>

SOLAr:MARgin (Set) → → (Query)

Description	Set or query solar margin ,unit:%
Syntax	SOLAr:MARgin<NR1>
Query Syntax	SOLAr:MARgin?
Parameter/ Return Parameter	<NR1>

SOLAr:MODE (Set) → → (Query)

Description	Set or query solar mode
Syntax	SOLAr:MODE{CC CV}
Query Syntax	SOLAr:MODE?
	CV

Set →

→ Query

SOLAr:SPEEd

Description	Set or query solar speed
Syntax	SOLAr:SPEEd<NR1>
Query Syntax	SOLAr:SPEEd?
Parameter/ Return Parameter	<NR1>

BASIMULAR System

BASIMular:BATtery:BASImular:S100	207
BASIMular:CAPAcity	208
BASIMular:RESistance.....	208
BASIMular:VMax.....	208
BASIMular:VSt	208
BASIMular:VMin	209
BASIMular:SERial	209
BASIMular:PARAllel.....	209
BASIMular:SINtial	209
BASIMular:ICHarge.....	210
BASIMular:IDIScharge.....	210
BASIMular:SLIMit	210
BASIMular:CSHw.....	211
BASIMular:S0~S100.....	211

BASIMular:BATtery:BASImular:S100

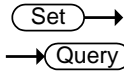

Description	Set or query battery simulation battery type
Syntax	BASIMular:BATtery<NR1>
Query Syntax	BASIMular:BATtery?
Parameter/ Return Parameter	<NR1> <ul style="list-style-type: none"> 0: Lithium manganate LMO, 1: lithium cobaltate LCO, 2: lithium iron phosphate LFO, 3: ternary lithium NCM, 4: Lithium Titanate LTO, 5: lead-acid battery Pb, 6: NiMH battery, 7: NiCd battery, 8: custom battery

Set →
 → Query

BASImular:CAPacity

Description	Set or query battery simulation capacity, unit is 0.1Ah
Syntax	BASImular:CAPacity<NR2>
Query Syntax	BASImular:CAPacity?
Parameter/ Return Parameter	<NR2>

Set →
 → Query

BASImular:RESistance

Description	Set or query battery simulation resistance. Unit is Ω
Syntax	BASImular:RESistance<NR2>
Query Syntax	BASImular:RESistance?
Parameter/ Return Parameter	<NR2>

Set →
 → Query

BASImular:VMax

Description	Set or query battery simulation vol max. Unit is V
Syntax	BASImular:VMax<NR2>
Query Syntax	BASImular:VMax?
Parameter/ Return Parameter	<NR2>

Set →
 → Query

BASImular:VSt

Description	Set or query battery simulation vol standard. Unit is V
Syntax	BASImular:VSt<NR2>
Query Syntax	BASImular:VSt?

Parameter/ Return Parameter <NR2>

Set →
→ Query

BASImular:VMin

Description Set or query battery simulation vol min, unit is V

Syntax BASImular:VMin<NR2>

Query Syntax BASImular:VMin?

Parameter/ Return Parameter <NR2>

Set →
→ Query

BASImular:SERial

Description Set or query battery simulation serial count

Syntax BASImular:SERial<NR1>

Query Syntax BASImular:SERial?

Parameter/ Return Parameter <NR1>

Set →
→ Query

BASImular:PARAllel

Description Set or query battery simulation parallel count

Syntax BASImular:PARAllel<NR2>

Query Syntax BASImular:PARAllel?

Parameter/ Return Parameter <NR2>

Set →
→ Query

BASImular:SINItial

Description Set or query battery simulation SOC initial. Unit is %

Syntax BASImular:SINItial<NR2>

Query Syntax BASImular:SINItial?

Parameter/ Return Parameter	<NR2>
--------------------------------	-------

Set →
→ Query

BASImular:ICHarge

Description	Set or query battery simulation charge max current. Unit is A
Syntax	BASImular:ICHarge<NR2>
Query Syntax	BASImular:ICHarge?

Parameter/ Return Parameter	<NR2>
--------------------------------	-------

Set →
→ Query

BASImular:IDIScharge

Description	Set or query battery simulation discharge max current. Unit is A
Syntax	BASImular:IDIScharge<NR2>
Query Syntax	BASImular:IDIScharge?

Parameter/ Return Parameter	<NR2>
--------------------------------	-------

Set →
→ Query

BASImular:SLIMit

Description	Set or query battery simulation SOC limit
Syntax	BASImular:SLIMit<NR1>
Query Syntax	BASImular:SLIMit?

Parameter/ Return Parameter	0	Limit
	1	Stop

Set →
 → Query

BASImular:CSHOW

Description	Set or query battery simulation curve shows	
Syntax	BASImular:CSHOW<NR1>	
Query Syntax	BASImular:CSHOW?	
Parameter/ Return Parameter	0	Discharge
	1	Charge

Set →
 → Query

BASImular:S0~S100

Description	Set or query battery simulation SOC 0%. Unit is V	
Syntax	BASImular:S0~S100<NR2>	
Query Syntax	BASImular:S0~S100?	
Parameter/ Return Parameter	<NR2>	

CHARGE System

CHARge:MODE	212
CHARge:OVP	213
CHARge:UCHARge.....	213
CHARge:ICHARge	213
CHARge:PCHARge	213
CHARge:COCurrent	214
CHARge:COTSwitch	214
CHARge:COTHour	214
CHARge:COTMinute	214
CHARge:COTSecond.....	215
CHARge:COASwitch	215
CHARge:COAAh	215
CHARge:IDIScharge	215
CHARge:PDIScharge	216
CHARge:DOVoltage	216
CHARge:DOTSwitch.....	216
CHARge:DOTHour.....	217
CHARge:DOTMinute.....	217
CHARge:DOTSecond	217
CHARge:DOASwitch	217
CHARge:DOAAh.....	218

CHARge:MODE

Set →

→ Query

Description	Set or query operation mode under charge and discharge mode.	
Syntax	CHARge:MODE<NR1>	
Query Syntax	CHARge:MODE?	
Parameter/ Return Parameter	0	Discharge
	1	Charge

CHARge:OVP
 →
 →

Description	Set or query OVP under charge and discharge mode. Unit is V
Syntax	CHARge:OVP<NR2>
Query Syntax	CHARge:OVP?
Parameter/ Return Parameter	<NR2>

CHARge:UCHARge
 →
 →

Description	Set or query charge voltage under charge and discharge mode. Unit is V
Syntax	CHARge:UCHARge<NR2>
Query Syntax	CHARge:UCHARge?
Parameter/ Return Parameter	<NR2>

CHARge:ICHARge
 →
 →

Description	Set or query charge current under charge and discharge mode. Unit is A.
Syntax	CHARge:ICHARge<NR2>
Query Syntax	CHARge:ICHARge?
Parameter/ Return Parameter	<NR2>

CHARge:PCHARge
 →
 →

Description	Set or query charge power under charge and discharge mode. Unit is kW.
Syntax	CHARge:PCHARge<NR2>
Query Syntax	CHARge:PCHARge?

Parameter/ Return Parameter	<NR2>
--------------------------------	-------

Set →
→ Query

CHARge:COCUrrent

Description	Set or query charge cutoff current under charge and discharge mode. Unit is A.
-------------	--

Syntax	CHARge:COCUrrent<NR2>
Query Syntax	CHARge:COCUrrent?

Parameter/ Return Parameter	<NR2>
--------------------------------	-------

Set →
→ Query

CHARge:COTSwitch

Description	Set or query state of charge cutoff time switch under charge and discharge mode.
-------------	--

Syntax	CHARge:COTSwitch<NR1>
Query Syntax	CHARge:COTSwitch?

Parameter/ Return Parameter	0 ON
	1 OFF

Set →
→ Query

CHARge:COTHour

Description	Set or query the hour numbers of charge cutoff time under charge and discharge mode, unit is h.
-------------	---

Syntax	CHARge:COTHour<NR1>
Query Syntax	CHARge:COTHour?

Parameter/ Return Parameter	<NR1>
--------------------------------	-------

Set →
→ Query

CHARge:COTMinute

Description	Set or query the minute numbers of charge cutoff time under charge and discharge mode, unit is m.
-------------	---

Syntax CHARge:COTMinute<NR1>
 Query Syntax CHARge:COTMinute?

Parameter/
 Return Parameter <NR1>

Set →
 → Query

CHARge:COTSecond

Description Set or query the second numbers of charge cutoff time under charge and discharge mode, unit is s.

Syntax CHARge:COTSecond<NR1>
 Query Syntax CHARge:COTSecond?

Parameter/
 Return Parameter <NR1>

Set →
 → Query

CHARge:COASwitch

Description Set or query state of charge cutoff Ah switch under charge and discharge mode.

Syntax CHARge:COASwitch<NR1>
 Query Syntax CHARge:COASwitch?

Parameter/ Return Parameter	0	OFF
	1	ON

Set →
 → Query

CHARge:COAAh

Description Set or query charge cutoff Ah value under charge and discharge mode. Unit is A.

Syntax CHARge:COAAh<NR2>
 Query Syntax CHARge:COAAh?

Parameter/
 Return Parameter <NR2>

Set →
 → Query

CHARge:IDIScharge

Description Set or query discharge current under charge and discharge mode. Unit is A.

Syntax CHARge:IDISCharg<NR2>
Query Syntax CHARge:IDISCharg?

Parameter/
Return Parameter <NR2>

Set →

→ Query

CHARge:PDISCharg

Description Set or query discharge power under charge and discharge mode. Unit is kW

Syntax CHARge:PDISCharg<NR2>
Query Syntax CHARge:PDISCharg?

Parameter/
Return Parameter <NR2>

Set →

→ Query

CHARge:DOVoltage

Description Set or query discharge voltage under charge and discharge mode. Unit is V.

Syntax CHARge:DOVoltage<NR2>
Query Syntax CHARge:DOVoltage?

Parameter/
Return Parameter <NR2>

Set →

→ Query

CHARge:DOTSwitch

Description Set or query state of discharge cutoff time switch under charge and discharge mode.

Syntax CHARge:DOTSwitch<NR1>
Query Syntax CHARge:DOTSwitch?

Parameter/ Return Parameter	0	ON
	1	OFF

CHARge:DOTHour



Description Set or query the hour numbers of discharge cutoff time under charge and discharge mode. Unit is h.

Syntax CHARge:DOTHour<NR1>
 Query Syntax CHARge:DOTHour?

Parameter/
 Return Parameter <NR1>

CHARge:DOTMinute



Description Set or query the minute numbers of discharge cutoff time under charge and discharge mode. Unit is m.

Syntax CHARge:DOTMinute<NR1>
 Query Syntax CHARge:DOTMinute?

Parameter/
 Return Parameter <NR1>

CHARge:DOTSecond



Description Set or query the second numbers of discharge cutoff time under charge and discharge mode. Unit is s.

Syntax CHARge:DOTSecond<NR1>
 Query Syntax CHARge:DOTSecond?

Parameter/
 Return Parameter <NR1>

CHARge:DOASwitch



Description Set or query state of discharge cutoff Ah switch under charge and discharge mode.

Syntax	CHARge:DOASwitch<NR1>	
Query Syntax	CHARge:DOASwitch?	
Parameter/ Return Parameter	0	ON
	1	OFF

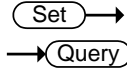
CHARge:DOAAh



Description	Set or query discharge cutoff Ah value under charge and discharge mode. Unit is A.	
Syntax	CHARge:DOAAh<NR2>	
Query Syntax	CHARge:DOAAh?	
Parameter/ Return Parameter	<NR2>	

SYSTEM Subsystem

SYSTem:ERRor.....	219
SYSTem:VERSIon.....	219

SYSTem:ERRor → Query

Description	Query command error cause	
Query Syntax	SYSTem:ERRor?	
Query return parameters	NONE	None
	FORMAT	Format
	RANGE	Range
	EXCEED	Exceed
	EXE	Execution

SYSTem:VERSIon → Query

Description	Query software version	
Query Syntax	SYSTem:VERSIon?	
Query return parameters	V1.00c	Control version no.
	V1.00d	Display version no.

Supplementary Description of the communication protocol

CAN communication protocol J1939 protocol is optional. If necessary, please ask the manufacturer for the protocol form.

It is recommended to use the RBS communication protocol. The host computer software for power supply selection uses the RBS protocol. It is more suitable than other protocols in terms of frequency of use and completeness.

PC Control Software

The PC software uses the RBS protocol of the power supply as the connection protocol, and the communication interface supports RS232, RS485, LAN interface, but does not support other interfaces such as CAN.

The software is installed in Chinese by default. You can switch to the English version by following the following paths: Menu → Setting → Language → English

Introduction to host computer control software

Figure I-6-1 shows the PC control software configured for the power supply. The software can remotely control power supply routine, sequence, photovoltaic and other routine functions.



I-6-1 PC control software - Power control page

The PC software also has the function of real-time data recording, can record the power online data, and automatically save to the file, can browse through the image, can be exported as a form file to facilitate data processing.

The PC software has the photovoltaic simulation function of MPPT(maximum power point tracking) and other functions, extended SAS, EN50530, Sandia and other law tests, can be directly operated in the single photovoltaic page.

The PC software also has the PV sequence test function, which can realize the photovoltaic automatic change test requirements, and can be directly operated in the single photovoltaic page-PV sequence.

The power supply has the automatic dynamic and static test function of EN50530, Sandia and other rules, which greatly simplifies the operation of the test process. You can click the working mode - photovoltaic MPPT test and switch to the photovoltaic MPPT test page (as shown in Figure I-6-2).

CGC/GF004 has the same definition of dynamic efficiency test mode as EN50530, so you can directly use the corresponding page of EN50530 if you need this standard test.

The PC software provides the cloud shading and cloud shifting functions of the PV simulation function (see Figure I-6-3).

The PC software has weather simulation and other functions.

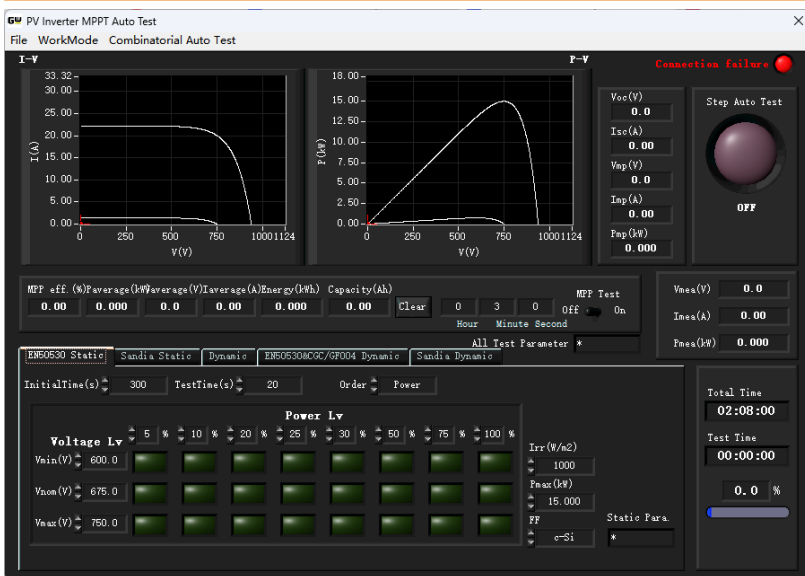

I-6-2 PC control software - PV MPPT test screen

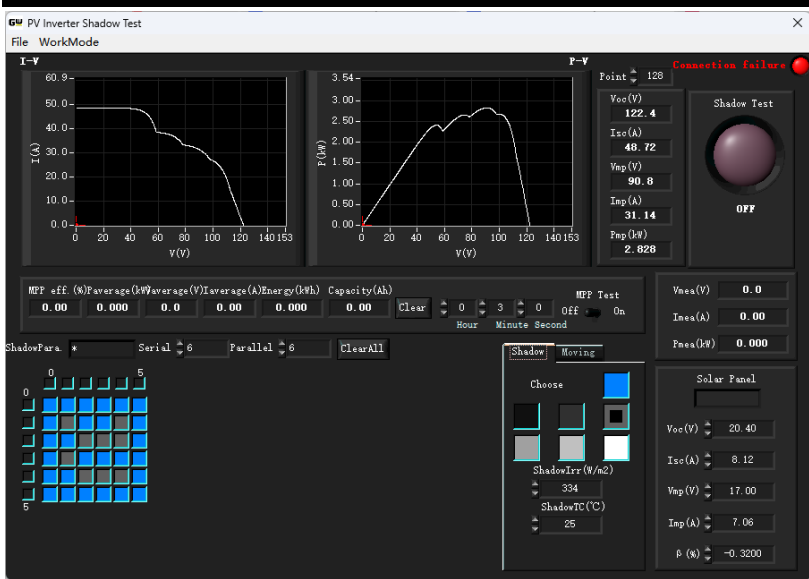

I-6-3 PC control software - PV shadow screen

Installation Description of the PC control software

When installing the software, use the “administrator” and execute the Setup.exe file in the folder (if it is a compressed package, decompress it).

The PC control software is suitable for Win7Sp1 and above Windows system.

For Windows 10 and later systems, change the drive letter in the installation directory to drive D or drive E (not drive C) during installation; otherwise, file read and write operations may be abnormal. If you still have problems reading and writing files, in addition to changing the drive letter in the installation directory to drive D or drive E (not drive C), please also use the “administrator” to open the application attempt (some win system “administrator” can read and write files normally, but some “administrator” can not operate files normally, please pay attention to the combination of attempts).

In addition, the MPPT automatic mode can export office form files, which requires the support of Office tools. If you need this function, please install Office software.

Connecting the PC control software

Dc power Change the “Communication protocol” option in the menu → Settings → Communication protocol page to “RBS” communication protocol.

On the PC control software, click Menu-Setting-Port Settings to ensure that the power address shown in Figure I-6-4 is consistent with “Protocol Address” on the DC power Communication Protocol page. The communication interface, baud rate/ IP address, and port number are consistent with the options on the Menu → Setting → Communication Interface page.

After setting the power supply, connect the power supply to the PC using the interface cable. Click Connect on the home screen. After the communication succeeds, the green light is displayed, and the power supply model is displayed, as shown in Figure I-6-5.



Note

Due to the product development process, the upper and lower machines are constantly expanding functions, there will be no normal connection caused by the version is not correct, please contact the manufacturer.

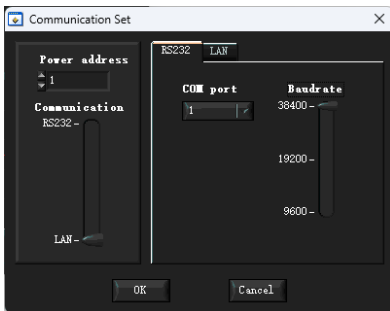

Figure I-6-4 Communication Settings



Figure I-6-5 The connection is successful

APPENDIX

Software version



No	Description
1	DSP chip firmware version
2	Display MEGA chip firmware version

Specifications

RBS05K-100, RBS10K-100, RBS15K-100, RBS05K-500, RBS10K-500, RBS15K-500

Output rating						
Model	RBS05K-100	RBS10K-100	RBS15K-100	RBS05K-500	RBS10K-500	RBS15K-500
Rated power	± 5000 W	± 10000 W	± 15000 W	± 5000 W	± 10000 W	± 15000 W
Rated voltage (source)	0 V to 100 V	0 V to 100 V	0 V to 100 V	0 V to 500 V	0 V to 500 V	0 V to 500 V
Operating voltage (sink)	5 V to 100 V	5 V to 100 V	5 V to 100 V	10 V to 500 V	10 V to 500 V	10 V to 500 V
Rated current	±170 A	±340 A	±510 A	±40 A	±80 A	±120 A

Output voltage							
Model	RBS05K-100	RBS10K-100	RBS15K-100	RBS05K-500	RBS10K-500	RBS15K-500	
Maximum settable voltage	100 V	100 V	100 V	500 V	500 V	500 V	
Setting accuracy	0.05 % + 0.05 %FS						
Setting resolution	0.01 V						
Load regulation CV	50 mV	50 mV	50 mV	150 mV	150 mV	150 mV	
Line regulation CV	15 mV	15 mV	15 mV	75 mV	75 mV	75 mV	
Temperature coefficient CV	100ppm						
Remote sensing (compensation voltage)	5 V	5 V	5 V	25 V	25 V	25 V	
Source only	Transient response *1		2 ms				
	Ripple noise	p-p *2	500 mV	500 mV	500 mV	600 mV	600 mV
		rms *3	35 mV	35 mV	35 mV	95 mV	95 mV
	Rise time *4	Full load	60 ms	60 ms	60 ms	30 ms	30 ms
		No load	15 ms				
	Fall time *5	Full load	15 ms				
No load		30 ms					

Output current						
Model	RBS05K-100	RBS10K-100	RBS15K-100	RBS05K-500	RBS10K-500	RBS15K-500
Settable maximum source current	170 A	340 A	510 A	40 A	80 A	120 A
Settable maximum sink current	-170 A	-340 A	-510 A	-40 A	-80 A	-120 A
Setting accuracy	0.4 %+0.4 %FS	0.4 %+0.4 %FS	0.4 %+0.4 %FS	0.15 %+0.15 %FS	0.15 %+0.15 %FS	0.15 %+0.15 %FS
Setting resolution	0.01 A					
Load regulation CC	340 mA	680 mA	1020 mA	40 mA	80 mA	120 mA
Line regulation CC	85 mA	170 mA	255 mA	20 mA	40 mA	60 mA
Ripple and noise *6	rms(*3)		0.1 %FS			
Temperature coefficient CC	200 ppm					

Output power						
Model	RBS05K-100	RBS10K-100	RBS15K-100	RBS05K-500	RBS10K-500	RBS15K-500
Settable maximum source power	5000 W	10000 W	15000 W	5000 W	10000 W	15000 W
Settable maximum sink power	-5000 W	-10000 W	-15000 W	-5000 W	-10000 W	-15000 W
Setting accuracy	0.5 % + 0.5 %FS					
Setting resolution	1 W					

DC Output Resistor						
Model	RBS05K-100	RBS10K-100	RBS15K-100	RBS05K-500	RBS10K-500	RBS15K-500
Resistance range	0 Ω to 100Ω	0 Ω to 100 Ω	0 Ω to 100 Ω	0 Ω to 500 Ω	0 Ω to 500 Ω	0 Ω to 500 Ω
Setting accuracy *7	≤ 5 %Rmax(0 to10 % Rmax); ≤ 10 %Rmax(10% to Rmax)					
Setting resolution	0.01 Ω					

Protective functions						
Model	RBS05K-100	RBS10K-100	RBS15K-100	RBS05K-500	RBS10K-500	RBS15K-500
OVP	Range	0 %FS to 110 %FS				
	Accuracy	0.1 %FS				
OCP	Range	0 %FS to 110%FS				
	Accuracy	0.2 %FS				
OTP	√					
Vsense reverse protection	√					
Input voltage protection (OVP, UVP)	√					

Display accuracy						
Model	RBS05K-100	RBS10K-100	RBS15K-100	RBS05K-500	RBS10K-500	RBS15K-500
Voltage	Accuracy	0.05 % + 0.05 %FS				
	Resolution	0.01 V				
Current	Accuracy	0.4 %+0.4 %FS	0.4 %+0.4 %FS	0.4 %+0.4 %FS	0.15 %+0.15 %FS	0.15 %+0.15 %FS
	Resolution	0.01 A				
Power	Accuracy	0.5 % + 0.5 %FS				
	Resolution	0.001 kW				

Interfaces digital						
Model	RBS05K-100	RBS10K-100	RBS15K-100	RBS05K-500	RBS10K-500	RBS15K-500
All-in-One(USB,RS232,RS485,CAN,LAN) (*8)	All-in-On/ GPIB					
GPIB(*8)	All-in-On/ GPIB					

400V three-phase three-wire input						
Model	RBS05K-100	RBS10K-100	RBS15K-100	RBS05K-500	RBS10K-500	RBS15K-500
Nominal input rating	380 Vac to 460 Vac					
Input voltage range	342 Vac to 510 Vac					
Input frequency range	47 Hz to 63 Hz					

Output Power		5000 W	10000 W	15000 W	5000 W	10000 W	15000 W
Input current (MAX)	at 342 Vac	9.2 A	18.4 A	27.6 A	9.2 A	18.4 A	27.6 A
Input power (MAX)		5.5 kVA	11 kVA	16.5 kVA	5.5 kVA	11 kVA	16.5 kVA
Power factor (TYP)		0.99					
Leakage current		5 mA					
Efficiency sink/source (up to)		93.00 %					

General Specifications							
Model		RBS05K-100	RBS10K-100	RBS15K-100	RBS05K-500	RBS10K-500	RBS15K-500
Environmental conditions	Operating temperature	0 °C to 40 °C					
	Operating humidity	20% to 90% RH					
	Storage temperature	-10 °C to 70 °C					
	Storage humidity	20% to 90% RH					
	Altitude	1000 m					
Withstand voltage	AC input to case (PE)	DC 2300 V					
Insulation resistance	Between output and GND	DC 500 V					
Mechanical construction	Dimensions (W x H x D) mm	482 mm x 133.3 mm x 790 mm					
	Weight	24 kg	32 kg	40 kg	24 kg	32 kg	40 kg
Parallel operation		√					

RBS05K-750, RBS10K-750, RBS15K-750, RBS10K-1000, RBS15K-1500, RBS15K-2250

Output rating							
Model		RBS05K-750	RBS10K-750	RBS15K-750	RBS10K-1000	RBS15K-1500	RBS15K-2250
Rated power		± 5000 W	± 10000 W	± 15000 W	± 10000 W	± 15000 W	± 15000 W
Rated voltage (source)		0 V to 750 V	0 V to 750 V	0 V to 750 V	0 V to 1000 V	0 V to 1500 V	0 V to 2250 V
Operating voltage (sink)		10 V to 750 V	10 V to 750 V	10 V to 750 V	10 V to 1000 V	10 V to 1500 V	10 V to 2250 V
Rated current		±25 A	±50 A	±75 A	±40 A	±40 A	±25 A

Output voltage							
Model		RBS05K-750	RBS10K-750	RBS15K-750	RBS10K-1000	RBS15K-1500	RBS15K-2250
Maximum settable voltage		750 V	750 V	750 V	1000 V	1500 V	2250 V
Setting accuracy		0.05 % + 0.05 %FS					
Setting resolution		0.1 V					
Load regulation CV		225 mV	225 mV	225 mV	300 mV	450 mV	675 mV
Line regulation CV		112.5 mV	112.5 mV	112.5 mV	150 mV	225 mV	337.5 mV
Temperature coefficient CV		100ppm					
Remote sensing (compensation voltage)		37.5 V	37.5 V	37.5 V	50 V	75 V	112.5 V

Source only		Transient response *1		2 ms				
Ripple noise	p-p *2	900 mV	900 mV	900 mV	1700 mV	2000 mV	6000 mV	
	rms *3	100 mV	100 mV	100 mV	295 mV	300 mV	400 mV	
Rise time *4	Full load	30 ms						
	No load	15 ms						
Fall time *5	Full load	15 ms						
	No load	30 ms						

Output current						
Model	RBS05K-750	RBS10K-750	RBS15K-750	RBS10K-1000	RBS15K-1500	RBS15K-2250
Settable maximum source current	25 A	50 A	75 A	40 A	40 A	25 A
Settable maximum sink current	-25 A	-50 A	-75 A	-40 A	-40 A	-25 A
Setting accuracy	0.15%+0.15%FS	0.15%+0.15%FS	0.15%+0.15%FS	0.15%+0.15%FS	0.15%+0.15%FS	0.2%+0.2%FS
Setting resolution	0.01 A					
Load regulation CC	25 mA	50 mA	75 mA	40 mA	40 mA	25 mA
Line regulation CC	12.5 mA	25 mA	37.5 mA	20 mA	20 mA	12.5 mA
Ripple and noise *6	rms(*3)	0.1 %FS	0.1 %FS	0.1 %FS	0.1 %FS	0.15 %FS
Temperature coefficient CC	200ppm					

Output power						
Model	RBS05K-750	RBS10K-750	RBS15K-750	RBS10K-1000	RBS15K-1500	RBS15K-2250
Settable maximum source power	5000 W	10000 W	15000 W	10000 W	15000 W	15000 W
Settable maximum sink power	-5000 W	-10000 W	-15000 W	-10000 W	-15000 W	-15000 W
Setting accuracy	0.5%+0.5%FS	0.5%+0.5%FS	0.5%+0.5%FS	0.5%+0.5%FS	0.5%+0.5%FS	1%+1%FS
Setting resolution	1 W					

DC Output Resistor						
Model	RBS05K-750	RBS10K-750	RBS15K-750	RBS10K-1000	RBS15K-1500	RBS15K-2250
Resistance range	0 Ω to 750 Ω	0 Ω to 750 Ω	0 Ω to 750 Ω	0 Ω to 1000 Ω	0 Ω to 1500 Ω	0 Ω to 2250 Ω
Setting accuracy *7	≤ 5 %Rmax(0 to 10 %Rmax); ≤ 10 %Rmax(10 % to Rmax)					
Setting resolution	0.01 Ω					

Protective functions						
Model	RBS05K-750	RBS10K-750	RBS15K-750	RBS10K-1000	RBS15K-1500	RBS15K-2250
OVP	Range	0 %FS to 110 %FS				
	Accuracy	0.1 %FS				
OCP	Range	0 %FS to 110 %FS				
	Accuracy	0.2 %FS				
OTP	√					
Vsense reverse protection	√					
Input voltage protection (OVP, UVP)	√					

Display accuracy							
Model		RBS05K-750	RBS10K-750	RBS15K-750	RBS10K-1000	RBS15K-1500	RBS15K-2250
Voltage	Accuracy	0.05 % + 0.05 %FS					
	Resolution	0.1 V					
Current	Accuracy	0.15%+0.15%FS	0.15%+0.15%FS	0.15%+0.15%FS	0.15%+0.15%FS	0.15%+0.15%FS	0.2%+0.2%FS
	Resolution	0.01 A					
Power	Accuracy	0.5 % + 0.5 %FS	0.5 % + 0.5 %FS	0.5 % + 0.5 %FS	0.5 % + 0.5 %FS	0.5 % + 0.5 %FS	1 % + 1 %FS
	Resolution	0.001 kW					

Interfaces digital							
Model		RBS05K-750	RBS10K-750	RBS15K-750	RBS10K-1000	RBS15K-1500	RBS15K-2250
All-in-One(USB,RS232,RS485,CAN,LAN) (*8)		All-in-On/ GPIB					
GPIB(*8)		All-in-On/ GPIB					

400V three-phase three-wire input							
Model		RBS05K-750	RBS10K-750	RBS15K-750	RBS10K-1000	RBS15K-1500	RBS15K-2250
Nominal input rating		380 Vac to 460 Vac					
Input voltage range		342 Vac to 510 Vac					
Input frequency range		47 Hz to 63 Hz					
Output Power		5000 W	10000 W	15000 W	10000 W	15000 W	15000 W
Input current (MAX)	at 342 Vac	9.2 A	18.4 A	27.6 A	18.4 A	27.6 A	27.6 A
Input power (MAX)		5.5 kVA	11 kVA	16.5 kVA	11 kVA	16.5 kVA	16.5 kVA
Power factor (TYP)		0.99					
Leakage current		5 mA					
Efficiency sink/source (up to)		93.00%					

General Specifications							
Model		RBS05K-750	RBS10K-750	RBS15K-750	RBS10K-1000	RBS15K-1500	RBS15K-2250
Environmental conditions	Operating temperature	0 °C to 40 °C					
	Operating humidity	20 % to 90 % RH					
	Storage temperature	-10 °C to 70 °C					
	Storage humidity	20 % to 90 % RH					
	Altitude	1000 m					
Withstand voltage	AC input to case (PE)	DC 2300 V					
Insulation resistance	Between output and GND	DC 500 V					
Mechanical construction	Dimensions (W x H x D) mm	482 mm x 133.3 mm x 790 mm					
	Weight	24 kg	32 kg	40 kg	32 kg	40 kg	40 kg
Parallel operation		√					

Note

- *1 When the load changes from 50% to 100%, or from 100% to 50%, the voltage returns to within 0.75% of the rating.
- *2 Measurement frequency bandwidth is 20 Hz to 20 MHz.
- *3 Measurement frequency bandwidth is 20 Hz to 2 MHz.
- *4 First set the 0V output, from 10% to 90% of the rated output voltage, with pure resistance.
- *5 Rated voltage output, then set to 0V, from 90% to 10% of rated output voltage, with pure resistance.
- *6 The ripple is measured at 20% to 100% output voltage and full output current. Source mode is 0.1%FS, Sink and Load mode is 0.2%FS.
- *7 When the input voltage is within 10% to 100% of the RBS voltage range and the load current is within 10% to 100% of the RBS current range.
- *8 Communication interface: one of two, factory-installed.

RBS Dimensions

The RBS models are available in two sizes, depending on the output voltage, with the difference being the size of the output voltage terminals.

RBS-HV (500V, 750V, 1000V, 1500V, 2250V)

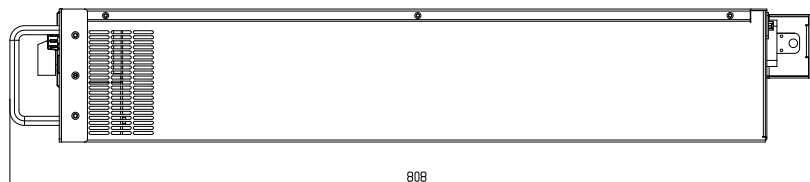
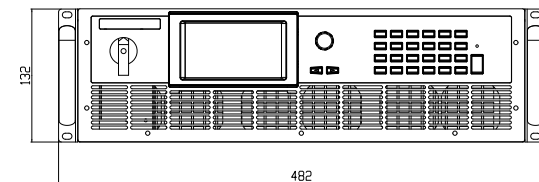
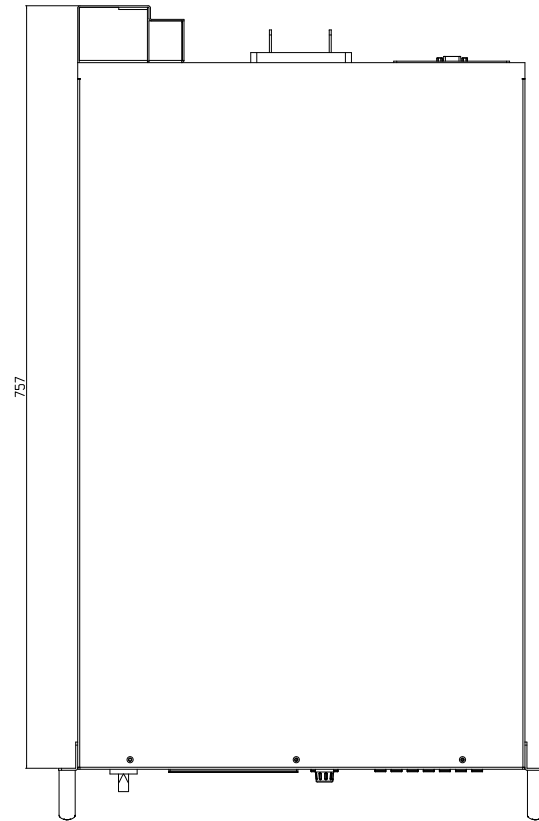

RBS-LV (100V)

