

1000A Precision Current Shunt Operation Manual



Material Contents Declaration

(材料含量宣称)

(Part Name) 零件名称	Hazardous Substance (有毒有害物质或元素)					
	铅 (Pb)	汞 (Hg)	镉 (Cd)	六价铬 (Cr6+)	多溴 联苯 (PBB)	多溴 二苯醚 (PBDE)
PCBA (印刷电路装配件)	X	0	X	0	0	0
Electrical part not on PCBA's 未在PCBA上的电子零件	X	0	X	0	0	0
Metal parts 金属零件	0	0	0	X	0	0
Plastic parts 塑料零件	0	0	0	0	X	X
Wiring 电线	X	0	0	0	0	0
Package 封装	X	0	0	0	0	0

对销售之日的所售产品,本表显示, PRODIGIT 供应链的电子信息产品可能包含这些物质。注意:在所售产品中可能会也可能不会含有所有所列的部件。This table shows where these substances may be found in the supply chain of Prodigit electronic information products, as of the date of sale of the enclosed product. Note that some of the component types listed above may or may not be a part of the enclosed product. 0: 表示该有毒有害物质在该部件所有均质材料中的含量均在SJ/T 11363-2006 标准规定的限量要求以下。○: Indicates that the concentration of the hazardous substance in all homogeneous materials in the parts is below the relevant threshold of the SJ/T 113632006 standard. x: 表示该有毒有害物质至少在该部件的某一均质材料中的含量超出SJ/T 11363-2006 标准规定的限量要求。x: Indicates that the concentration of the hazardous substance of at least one of all homogeneous materials in the parts is above the relevant threshold of the SJ/T 11363-2006 standard.

Note(注释):

1. Prodigit has not fully transitioned to lead-free solder assembly at this moment ; However, most of the components used are RoHS compliant.

(此刻, Prodigit 并非完全过渡到无铅焊料组装;但是大部份的元器件一至于RoHS的规定。)

2. The product is labeled with an environment-friendly usage period in years.

The marked period is assumed under the operating environment specified in the product specifications.

(产品标注了环境友好的使用期限限制(年)。所标注的环境使用期限假定是在此产品定义的使用环境之下。)



Example of a marking for a 10 year period:

(例如此标制环境使用期限为10年)

SAFETY SUMMARY

The following general safety precautions must be observed during all phases of operation, service, and repair of this instrument. Failure to comply with these precautions or with specific warnings elsewhere in this manual violates safety standards of design, manufacture, and intended use of the instrument. PRODIGIT assumes no liability for the *customer's failure to comply with these requirements*.

GENERAL

This product is a Safety Class 1 instrument (provided with a protective earth terminal). The protective features of this product may be impaired if it is used in a manner not specified in the operation instructions.

ENVIRONMENTAL CONDITIONS

This instrument is intended for indoor use in an installation category I, pollution degree 2 environments. It is designed to operate at a maximum relative humidity of 80% and at altitudes of up to 2000 meters. Refer to the specifications tables for the ac mains voltage requirements and ambient operating temperature range.

BEFORE APPLYING POWER

Verify that the product is set to match the available line voltage and the correct fuse is installed.

GROUND THE INSTRUMENT

This product is a Safety Class 1 instrument (provided with a protective earth terminal). To minimize shock hazard, the instrument chassis and cabinet must be connected to an electrical ground. The instrument must be connected to the ac power supply mains through a three conductor

power cable, with the third wire firmly connected to an electrical ground (safety ground) at the power outlet. Any interruption of the protective (grounding) conductor or disconnection of the protective earth terminal will cause a potential shock hazard that could result in personal injury.

FUSES

Only fuses with the required rated current, voltage, and specified type (normal blow, time delay, etc.) should be used. Do not use repaired

Fuses or short circuited fuse holder. To do so could cause a shock or fire hazard.

DO NOT OPERATE IN AN EXPLOSIVE ATMOSPHERE.

Do not operate the instrument in the presence of flammable gases or fumes.

KEEP AWAY FROM LIVE CIRCUITS.

Operating personnel must not remove instrument covers. Component replacement and internal adjustments must be made by qualified service personnel. Do not replace components with power cable connected. Under certain conditions, dangerous voltages may exist even with the power cable removed. To avoid injuries, always disconnect power, discharge circuits and remove external voltage sources before touching components.

DO NOT SERVICE OR ADJUST ALONE.

Do not attempt internal service or adjustment unless another person, capable of rendering first aid and resuscitation, is present.

DO NOT EXCEED INPUT RATINGS.

This instrument may be equipped with a line filter to reduce electromagnetic interference and must be connected to a properly grounded receptacle to minimize electric shock hazard.

Operation at line voltages or frequencies in excess of those stated on the data plate may cause leakage currents in excess of 5.0 mA peak.

DO NOT SUBSTITUTE PARTS OR MODIFY INSTRUMENT.

Because of the danger of introducing additional hazards, do not install substitute parts or perform any unauthorized modification to the instrument. Return the instrument to a PRODIGIT ELECTRONICS Sales and Service Office for service and repair to ensure that safety features are maintained.

Instruments which appear damaged or defective should be made inoperative and secured against unintended operation until they can be repaired by qualified service personnel.

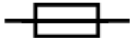
SAFETY SYMBOLS**Direct current (DC)****Alternating current (AC)****Both direct and alternating****Three-phase alternating current****Protective earth (ground)****On (Supply)****Off (Supply)****Fuse****Caution ! Refer to this manual before using the meter.****Caution, risk of electric shock**

CAT IV – Is for measurements performed at the source of the low-voltage installation.

CAT III – Is for measurements performed in the building installation.

CAT II – Is for measurements performed on circuits directly connected to the low-voltage installation.

CAT I – Is for measurements performed on circuits not directly connected to Mains.

This equipment is not for measurements performed for CAT II, III, and IV.



EC Declaration of Conformity

We **Prodigit Electronics Co., Ltd.** declares under our own responsibility that the product

Current Shunt

(Model No.: 1000A)

satisfies all the technical relations application to the product within the scope of council:

Directive: 2014/30/EU; 2014/35/EU; 2015/863/EU; 2012/19/EU

The above product is in conformity with the following standards or other normative documents

Harmonized Standard :

EN 61010-1: 2010+A1:2019

EN IEC 61010-2-030:2021+A11:2021

EN 61326-1:2013

EN 61326-2-1:2013

Reference Basic Standards :

Emission:

EN 55011: 2016+A1: 2020 Class A

EN 55032: 2015+A1:2020

EN 61000-3-2: 2014

EN 61000-3-3: 2013

Immunity:

EN 61000-4-2: 2009

EN 61000-4-3: 2006+A2:2010

EN 61000-4-4: 2012

EN 61000-4-5: 2014+A1:2017

EN 61000-4-6: 2014

EN 61000-4-8: 2010

EN 61000-4-11: 2020

Company Name: Prodigit Electronics Co., Ltd

**Company Address: 8F, No.88, Baojhong Rd., Sindian District, New Taipei
City, Taiwan.**

Person is responsible for marking this declaration:



Manufacturer/Importer
Signature

Date: **2022/10/20** Name:

Dean Wang

Dean Wang
R&D Assistant Manager

UK CA UK Declaration of Conformity

We Prodigit Electronics Co., Ltd. declares under our own responsibility that the product

Current Shunt

(Model No.: 1000A)

satisfies all the technical relations application to the product within the scope of council:

Directive: **Electromagnetic Compatibility Regulations 2016; Electrical Equipment (Safety) Regulations 2016; the Restriction of the Use of Certain Hazardous Substances in Electrical and Electronic Equipment Regulations 2012**

The above product is in conformity with the following standards or other normative documents

Harmonized Standard :

BS EN 61010-1:2010+A1:2019 ;BS EN IEC 61010-2-030:2021+A11:2021

BS EN 61326-1: 2013 ; BS EN 61326-2-1: 2013

Reference Basic Standards :

Emission:

BS EN 55011: 2016+A1: 2020 Class A

BS EN 55032: 2015+A1:2020

BS EN 61000-3-2: 2014

BS EN 61000-3-3: 2013

Immunity:

BS EN 61000-4-2: 2009

BS EN 61000-4-3: 2006+A2:2010

BS EN 61000-4-4: 2012

BS EN 61000-4-5: 2014+A1:2017

BS EN 61000-4-6: 2014

BS EN 61000-4-8: 2010

BS EN 61000-4-11: 2020

Company Name: Prodigit Electronics Co., Ltd

Company Address: 8F, No.88, Baojhong Rd., Sindian District, New Taipei City, Taiwan.

Person is responsible for marking this declaration:



Manufacturer/Importer
Signature

Date: **2022/10/20** Name:

Dean Wang

Dean Wang
R&D Assistant Manager

1000A Precision Current Shunt Operation Manual

Table of Contents

Chapter 1 General information	8
1-1. Introduction	8
1-2. Specifications	8
1-3. Accessories	10
1-4. Options.....	10
Chapter 2 Installation	11
2-1 Check line voltage	11
2-2 Input Fuse	11
2-3 Grounding requirements.....	12
2-4 Environmental Requirements	13
2-5 Observe the International Electrical Symbol Listed Below	13
2-6 Cleaning	13
2-7 Current shunt Placement.....	13
2-8 Power Up	14
2-9 GPIB & RS232 connection option.....	14
2-10 RS232 Interface Option	14
2-11 GPIB connection option.....	15
2-12 USB connection option	16
2-13 LAN Connection Option.....	16
2-14 Range Output.....	16
Chapter 3 Operation	18
3-1. 1000A current shunt Size description	18
3-2. Front panel description	19
3-3. Instructions.....	19
3-4. Protect.....	22
Chapter 4 Remote control programming operation	23
4.1 Introduction	23
4.2 The summary of GPIB command.....	23
4.3 The summary of RS-232 Interface and command	23
4.4 1000A REMOTE CONTROL COMMAND LIST	24
4.5 The description of abbreviation.....	24
4.6 Remote Control Command Language description	25
4.7 Remote control command description	25
Appendix A 1000A USB Instruction	27
Appendix B: 1000A LAN Installation	29

Chapter 1 General information

1-1. Introduction

The model 1000A precision current shunt is a precision AC/DC shunt. It incorporates five shunt ranges from 1 Ω , 0.1 Ω , 0.01 Ω , 0.001 Ω to 0.0001 Ω . The AC/DC measuring current range from 200mA, 2A, 20A, 200A to 1000A full scale and a built-in 5 1/2 digit precision AC/DC current meter with AUTO-ZERO and AUTO-RANGE function. Each shunt range has its own a select key provides access to the voltage output terminals of each shunt resistor. A single set of binding post conveniently provides output voltage to the measuring voltmeter.



The compliance voltage of the shunt is less than 0.2 volts at full scale for each range except the 1000 Ampere range which has a compliance voltage of 0.1 volts. The shunt is a highly stable AC/DC resistor connected in a four-terminal non-inductive configuration for each range except the 1000A range.

1-2. Specifications

SHUNT all types are 4 terminal networks with calibration adjustments for each network.

Specifications							
Range	Shunt Value	*DC Accuracy		*AC Accuracy \leq 400Hz		Max input DC/AC rms	Output Voltage
		Typ.	Max.				
1000A	0.0001 Ω	0.02% of Reading + 0.01% of Range	0.05% of Reading + 0.05% of Range	50~200 Hz	0.1% (Reading + Range)	1000 A	1000A / 0.1V
				201~300 Hz	0.2% (Reading + Range)		
				301~400 Hz	0.4% (Reading + Range)		
200A	0.001 Ω	0.02% of Reading	0.04% of Reading	0.10% of Reading		250 A	200A / 0.2V
20A	0.01 Ω	0.01% of Reading	0.02% of Reading	0.10% of Reading		30 A	20A / 0.2V
2A	0.1 Ω	0.01% of Reading	0.02% of Reading	0.10% of Reading		4 A	2A / 0.2V
0.2A	1 Ω	0.01% of Reading	0.02% of Reading	0.10% of Reading		0.4 A	0.2A / 0.2V

5 1/2 Digit Ampere Meter					
Range	Resolution	*DC		*AC(50Hz~400Hz)	
		Accuracy ± (% of reading + of Range)			
		Typ.	Max.		
1000A	0.01 A	0.04+0.02	0.1+0.05	50~200 Hz	0.5+0.1
				201~300 Hz	0.5+0.2
				301~400 Hz	0.5+0.4
200A	0.001 A / 0.01A	0.04+0.01	0.08+0.01	0.5+0.05	
20A	0.0001 A / 0.001A	0.02+0.01	0.04+0.01	0.5+0.05	
2A	0.01mA / 0.1mA	0.02+0.01	0.04+0.01	0.5+0.05	
0.2A	0.001mA / 0.01mA	0.02+0.01	0.04+0.01	0.5+0.05	

*AC accuracy is limited to 100A.

*AC input : Range 0.2A、2A、20A、200A ≥ 5% of Range
 Range 1000A ≥ 10% of Range

*The specifications apply when the 1000A is powered on for at least 30 minutes

*The typical not apply when 20A, 200A, 1000A use over 50% range current and over 3 mins or the ON/OFF current period ratio less than 1/3.

*For high accuracy measurement please use the 6 1/2 D.V.M. to measure the voltage output which is proportional to the current value and suggest 6 1/2 D.V.M. away form shunt at least 120cm.

General information's :	
Temperature range :	0 to 40°C; stated accuracy for 1 year at 23°C±2°C.
Temperature coefficient :	Range 0.2A、2A Less than 0.001% per °C (20 °C - 40 °C)
	Range 20A Less than 0.002% per °C (20 °C - 40 °C)
	Range 200A Less than 0.003% per °C (20 °C - 40 °C)
	Range 1000A Less than 0.005% per °C (20 °C - 40 °C)

AC INPUT	LINE	115Vac/ 230Vac ± 10%
	FREQUENCY	50/60 Hz
	PROTECT	FUSE
	MAX. POWER CONSUMPTION	25W

Table 1-1 1000A Specifications

Model	Dimension(HxWxD)	WEIGHT
1000A	89 mm x 440 mm x 370 mm	13.5Kg

Table 1-2 1000A Dimensions

1-3. Accessories

PRODIGIT PART NO.	DESCRIPTIONS	Quantity
60300320	H5.5-8;HOOK TRML YEL INS #12-10	2
60510080	GDL1;FUUSE,5X20MM 1.00A, SLOW	1
60550081	GDL5;FUUSE ,5X20MM 5.00A SLOW	1
74100351	SCREW M8*1.25 L=35mm NI	4
74109000	RND SCREW M8*1.25 L=35mm NI	4
74500110	NUTS M8X12 X 6	6
74800070	WASHER INSIDE DIA-8.5 *22*1.5 OUTSIDE	12
74100350	SCREW M8*1.25 L=25mm NI	2
9001000A01	1000A Operation Manual	1
	*Power Cord	1

* Provide corresponding specifications according to different regions

1-4. Options

PRODIGIT PART NO.	DESCRIPTIONS	Quantity	NOTE
64180100	1 meter welding cable 80 SQMM	2	For 200A
709100002	Braided Connector L=1000mm	2	For 1000A
709200002	Braided Connector L=2000mm	2	
709300002	Braided Connector L=3000mm	2	
15060801	Rack mount kit	1	

Chapter 2 Installation

2-1 Check line voltage

The 1000A precision current shunt can be operated from a 100/115 or 200/230Vac input as indicated on the label on the rear panel. The input is switchable so please make sure that the switch is set correctly for your nominal mains input before turning on the mains power. The procedure below details how to change the switch position:

- 2.1.1 With the 1000A power OFF, disconnect the power cord.
 2.1.2 Refer the drawing on the rear panel in Fig 2-1, set the switches to the Proper voltage as described in the following:
 a. Set Switch to 100V/115V for 115Vac line voltage
 b. Set Switch to 200V/230V for 230Vac line voltage
 Note: 100Vac and 200Vac is used for Japan only (Option)

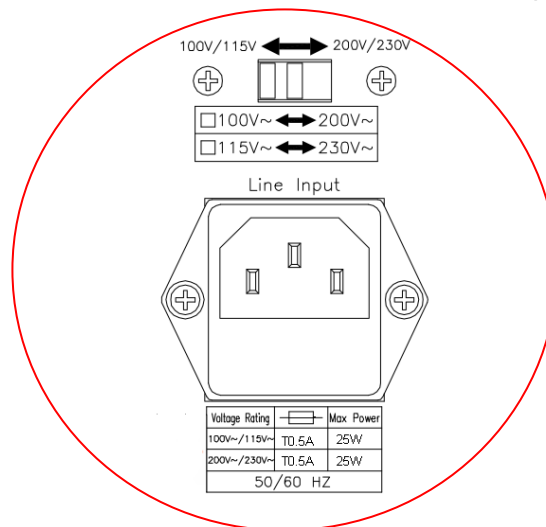

Fig 2-1 SET OF SWITCH

2-2 Input Fuse

This product is fitted with a mains input fuse. If it needs to be replaced please adhere to the Following procedure.



BEFORE replacing the fuse you must switch off the unit and mains power outlet and disconnect the plug of the AC Power cable from the input socket of the 1000A.



If prior to exchanging the fuse, there is any abnormal noise or odour do not use the unit. Please inform your local sales office to organise repair of the 1000A.

To avoid the risk of fire or electronic shock the fuse must only be replaced with same type and rating as the original. Any replacement fuse used should meet your national safety standards. Any use of improper fuse or shorting the Fuse holder would be extremely dangerous and would be strictly prohibited.

- 2.3.1 Check the rating of the mains input fuse. Replace only with the correct Type and rating.
 For 100V/115Vac Input use T0.5A/250V (5*20mm),
 For 200V/230Vac Input use T0.5A/250V (5*20mm)
- 2.3.2 The AC line fuse is located below the AC line socket (see Fig 2-2). Use A small screwdriver to remove the fuse holder. Replace the failed fuse With the appropriate type and rating according to your mains voltage. (See Table 1-1)
- 2.3.3 Refit the fuse holder and connect the power cord.

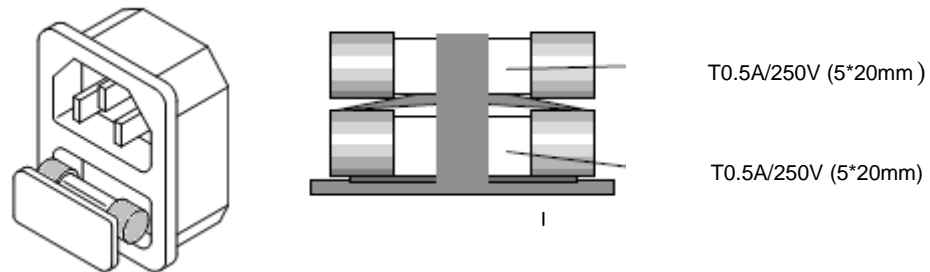

Fig 2-2 FUSE RECEPTACLE

2-3 Grounding requirements



SHOCK HAZARD

The unit is grounded via the AC Input. It must be ensured that the correct mains lead with earth pin is used. Correct grounding of your electrical system infrastructure according to national standards must also be observed.

2-4 Environmental Requirements

- Indoor use.
- Insulation Category I.
- Pollution Degree 2.
- Altitude up to 2000 meters
- Relative Humidity 80% Max (non-condensing).
- Ambient Temperature 0 to 40°C
- The ideal operating temperature is 25°C ± 5°C

2-5 Observe the International Electrical Symbol Listed Below

⚠ Warning ! Risk of electric shock.

⚠ Caution ! Refer to this manual before using the instrument.

2-6 Cleaning

To clean this product uses a soft or slightly damp cloth .

CAUTION

BEFORE you clean the unit, switch the mains power off and disconnect the input lead.

- Please do NOT use any organic solvent capable of changing the nature of the plastic such as benzene or acetone.
 - Please ensure that no liquid is allowed to penetrate this product.

2-7 Current shunt Placement

Place the Current shunt near the ground pin of the circuit. If this principle is not followed, the voltage drop generated by Current shunt may cause electric shock.

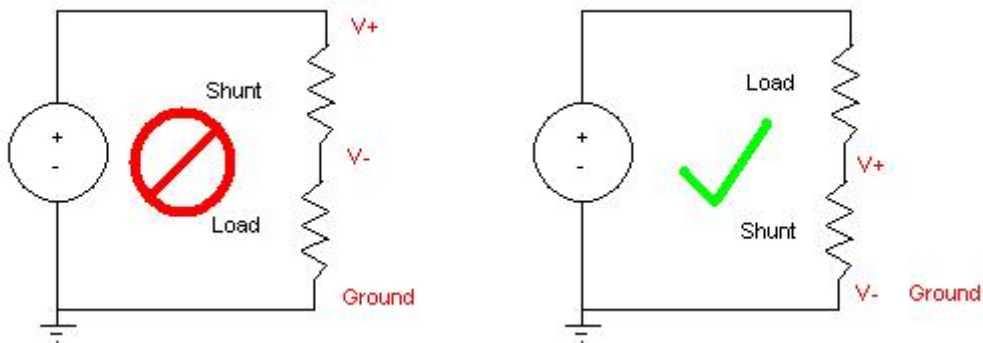

Fig 2-3 1000A Current shunt Placement

2-8 Power Up

The following procedure should be followed before applying mains power:

- Check that the POWER switch is in the off (O) position
- Check the rear panel voltage selector of the 1000A is correctly set.
- Connect correct AC mains lead to the 1000A
- Turn on (I) the POWER switch.

2-9 GPIB & RS232 connection option

If your 1000A is fitted with GPIB + RS232 interface card then the rear panel will have the necessary interface sockets as shown in Fig 2-3. This connects the 1000A mainframe to RS232 or GPIB port of your computer.

GPIB and RS232 interface can only be used at the same time, to Change the interface must reboot unit.



Fig 2-4 1000A REAR PANEL

A GPIB system can be connected in any configuration (star, linear, or both) as long as

- The maximum number of devices including the controller is no more than 15.
- The maximum length of the GPIB cable is no more than 2 meters.
- The total lead length of all devices connected together total <20 meters
- Setting GPIB address:
Hold AC/DC Key 3 Second. → Pass 2A Key or 20A Key to change the address
→ Pass AC/DC Key to save the new address.

2-10 RS232 Interface Option

Fig 2-4 shows the RS232 connector (Female) on the rear panel. This connects the 1000A to RS232 port of computer.



Fig 2-5 1000A RS232 Connection

2-11 GPIB connection option

The GPIB connector is located on the rear panel. This socket allows the 1000A to be connected to the controller and other GPIB devices. A GPIB system can be connected in any configuration (star, linear, or both) as long as

- The maximum number of devices including the controller is ≤ 15 .
- The maximum length of the GPIB cable is no more than 2 meters times.
- The total lead length of all devices connected together total < 20 meters.
- Please make sure the lock screws are firmly hand-tightened, use a Screwdriver only for the removal of screws. Fig 2-5 shows the rear Panel of 1000A mainframe, The GPIB address of the 1000A mainframe is set on Front panel.
- Setting GPIB address:
 Hold AC/DC Key 3 Second. → Pass 2A Key or 20A Key to change the address
 → Pass AC/DC Key to save the New address

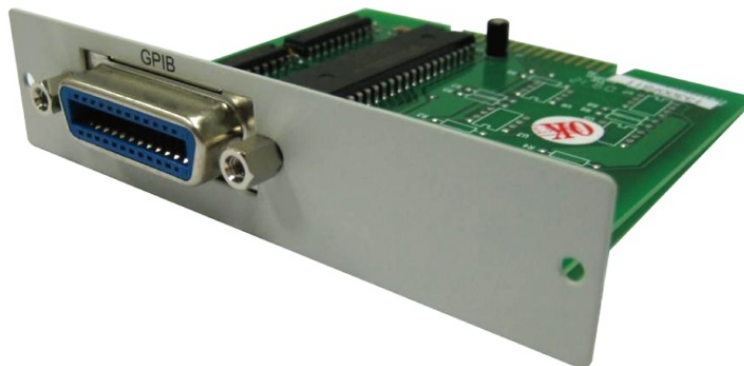

Fig 2-6 1000A REAR PANEL

2-12USB connection option

Fig 2-6 shows the USB connector in the rear panel of 1000A mainframe. Please refer Appendix A.



Fig 2-7 1000A USB Connection

2-13LAN Connection Option

Fig 2-7 shows the LAN connector in the rear panel of 1000A mainframe. Please refer Appendix B.

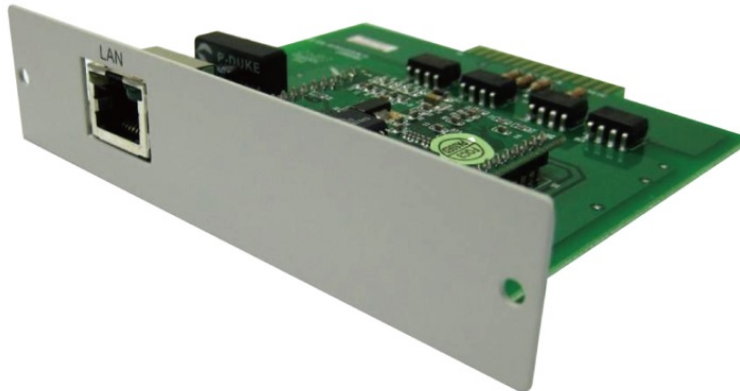

Fig 2-8 1000A LAN Connection

2-14Range Output

The RANGE OUTPUT connector of 1000A rear panel,

- Pin 1, 2: AC/DC (On: AC, OFF: DC)
- Pin 3, 4: POS/NEG (On: NEG, OFF: POS)
- Pin 5, 6: 0.2A (On: Range 0.2A)
- Pin 7, 8: 2A (On: Range 2A)
- Pin 9, 10: 20A (On: Range 20A)
- Pin 11, 12: 200A (On: Range 200A)
- Pin 13, 14: 1000A (On: Range 1000A)
- Pin 15: Reserved

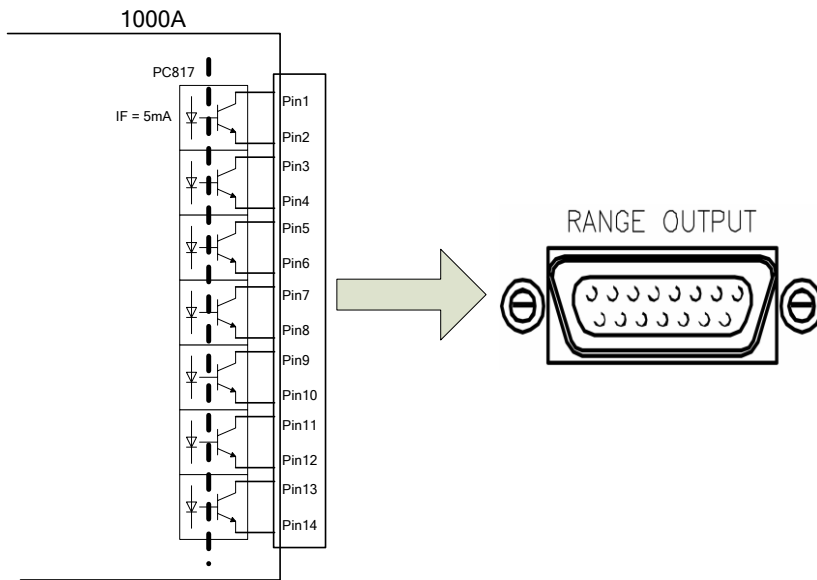

Fig 2-9 RS-232C RANGE OUTPUT CONNECTION OF REAR PANEL

Chapter 3 Operation

This chapter describes the front panel function and operation of each 1000A current shunt, and GPIB/RS232/LAN/USB programming.

3-1. 1000A current shunt Size description

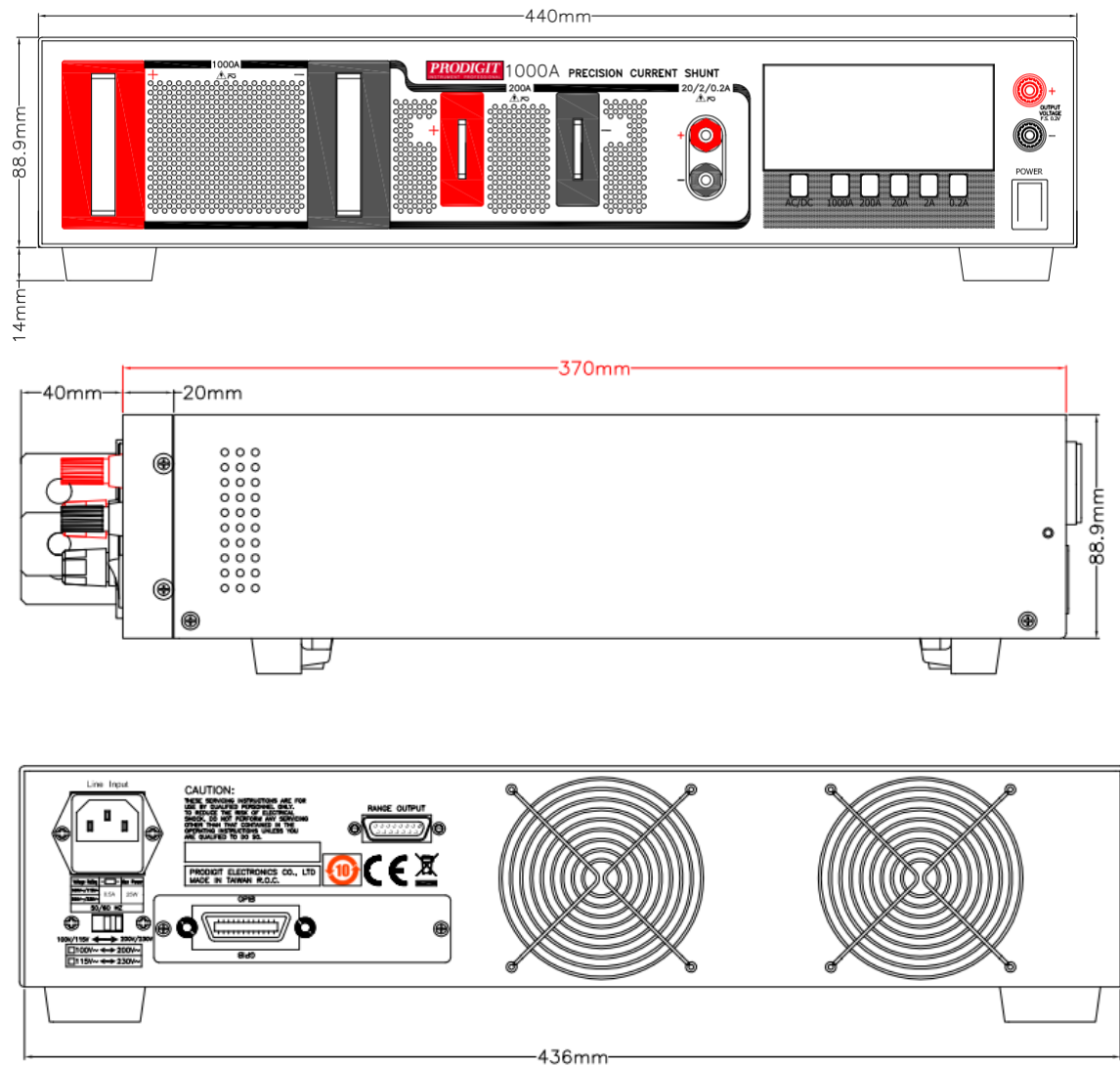
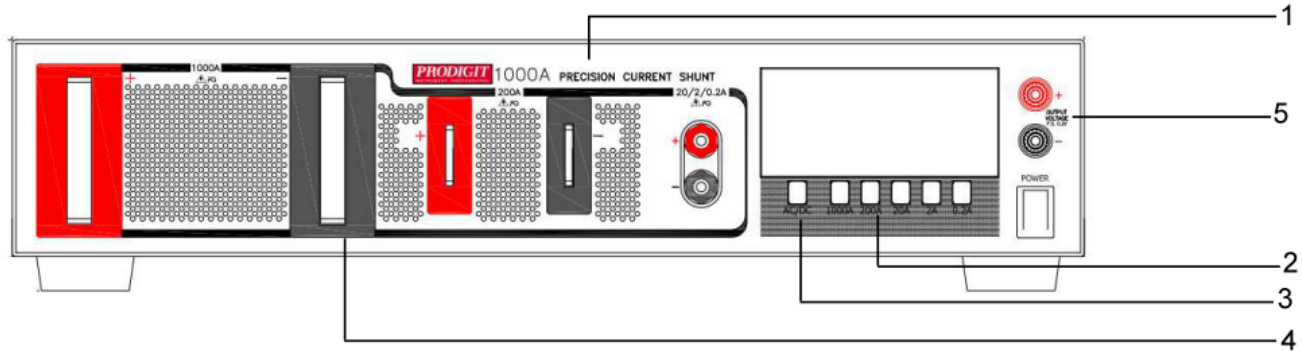

Fig 3-1 1000A SIZE description

3-2. Front panel description

The following sketch shows the layout of the front panel of the unit. Please refer to the relevant section as indicated by the number assigned to a front panel function.



3-3. Instructions

3.3.1. Model number and sink ranges

The model number along with maximum current values is detailed in this position
At the top of the current shunt front panel.

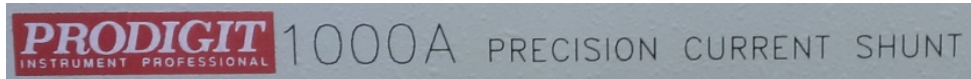

It indicates the model number and specifications of 1000A Current shunt.

3.3.2. Range Select

There are five operating range, the sequence is 1000A, 200A, 20A, 2A, 0.2A.
Pressing the "1000A" key on the 1000A current Shunt, the appropriate LCD will illuminate according to the operating range is selected.



Pressing the "200A" key on the 1000A current Shunt, the appropriate LCD will illuminate according to the operating range is selected.



Pressing the "20A" key on the 1000A current Shunt, the appropriate LCD will illuminate according to the operating range is selected.



Pressing the "2A" key on the 1000A current Shunt, the appropriate LCD will illuminate according to the operating range is selected.



Pressing the "0.2A" key on the 1000A current Shunt, the appropriate LCD will illuminate according to the operating range is selected.



3.3.3. AC/DC Select key

Pressing the "AC/DC" key on the 1000A current Shunt, the appropriate LCD will illuminate according to the operating AC or DC mode is selected.

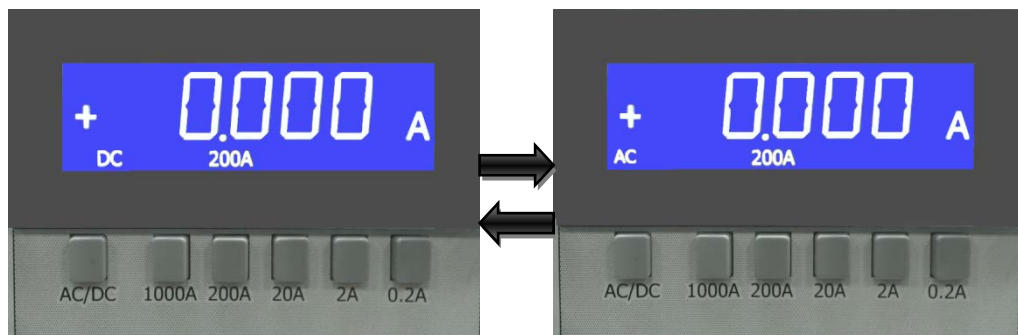

3.3.4. Current measurements

The 1000A use a four terminal current shunt configuration. Two terminals (CURRENT INPUT) are connecting the load in series with the panel terminals of the appropriate current shunt. Note the maximum current limit label on the panel. The RANGE selector key-switch is used to select the voltage sense terminals (VOLTAGE OUTPUT) and the 5 1/2 digit precision current meter. The VOLTAGE OUTPUT sense terminal and the 5 1/2 digit precision current meter are connected directly across the calibration adjustment divider of the shunt resistor selected by the RANGE key-switch.

3.3.5. Output

To measuring the load current can "direct reading" from 5 1/2 digit precision AC/DC current meter in normally application. For the higher accuracy & resolution Application, the OUTPUT voltage can be measured with a measuring device (Thermal transfer standard, 6 1/2) precision DVM, etc).

It is not necessary that a load connected to one range be disconnected when connecting a load to another range as the range key-switch isolates the shunts from one another.

3.3.6. Setting GPIB Address

Set the GPIB address you must press the AC/DC key three second. The LCD will display the current address.

Note: GPIB initial value of 06

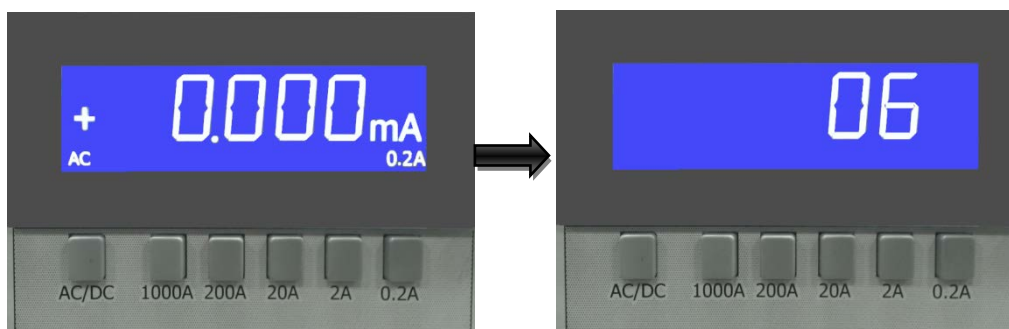

Press 2A (UP), 20A (down) buttons to adjust the GPIB address 1 to 31.

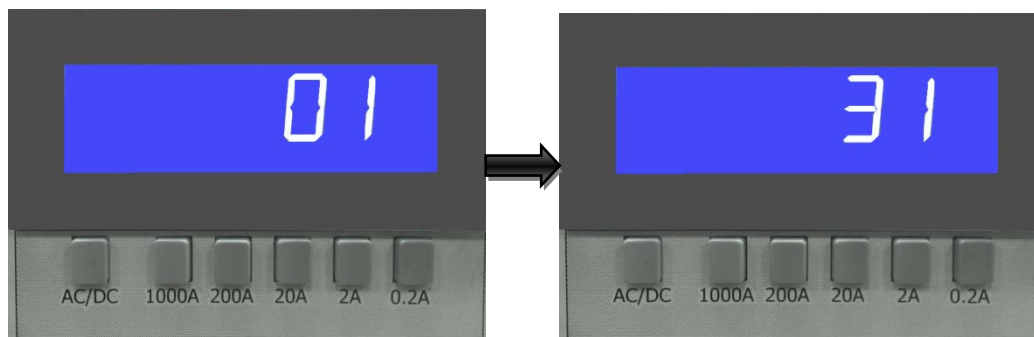

Once the required address is reached press AC/DC key to save the New Address and return to the normal screen.

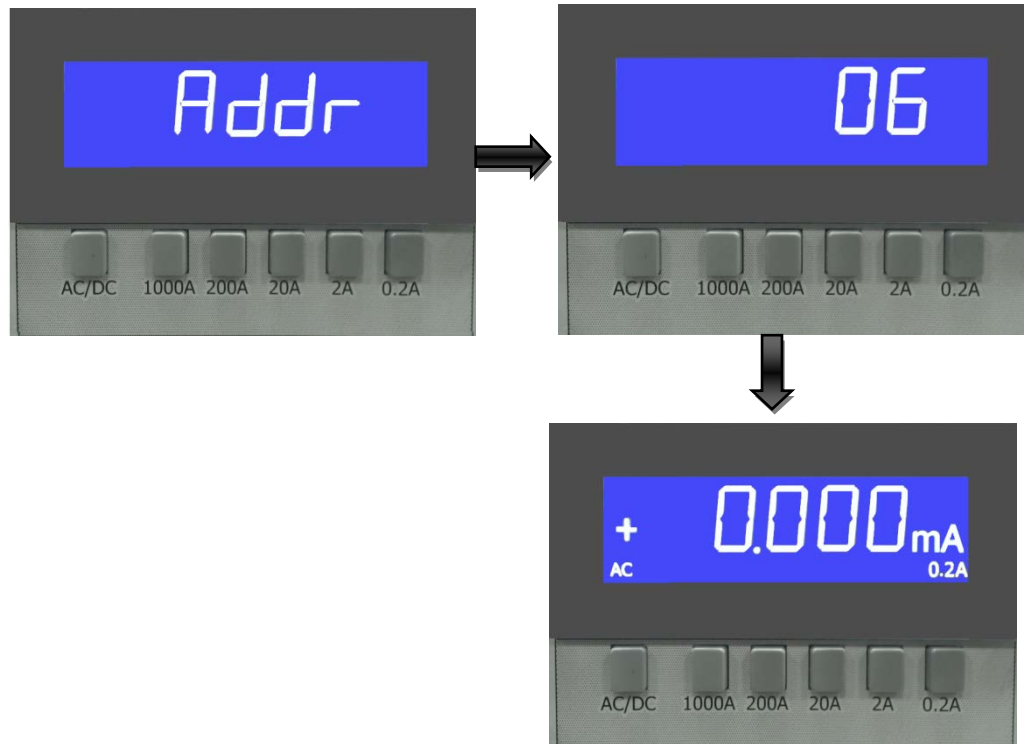

3-4. Protect

The protect device (current fuse) protects the 200mA and 2A range from an input current greater than 1A and 5A. To replace the current fuse, perform the following steps :

1. Turn off the power and disconnect all equipment.
2. Remove the top cover of instrument to replace the fuse. Top cover is removed by removing screws.
3. Remove the defective fuse and replace it with the recommended fuse.(See table 3-1) or equivalent.

PRODIGIT PART NO.	REF.	RANGE	DESCRIPTIONS
60510080	F2	200mA	1.0 A/250 V 5×20mm Slow Blow
60550081	F3	2 A	5.0 A/250 V 5×20mm Slow Blow

Table 3-1 recommended fuse

⚠ CAUTION : Use only the recommended fuse type. If a fuse with a higher current rating is installed, instrument damage may occur.

Chapter 4 Remote control programming operation

4.1 Introduction

The rear panel GPIB/RS-232 interface of 1000A mainframe is designed to connect PC or NOTEBOOK PC with GPIB/RS-232 interface, the NOTEBOOK PC acts as a remote controller of 1000A precision current shunt.

4.2 The summary of GPIB command

There're two syntax commands of 1000A to be selected. One is SIMPLE mode and the other is COMPLEX mode.

4.3 The summary of RS-232 Interface and command

The following RS-232 commands are same as GPIB commands. The RS-232 protocol in 1000A mainframe is listing below:

Baud-rate : 115200 bps

Parity : None

Data bit : 8 bits

Stop bit : 1 bit

Handshaking : Hardware (RTS/CTS).

The RS-232C Interface connector of 1000A rear panel, RS-232 is shown in Fig4-1.

Inside 1000A Current shunt

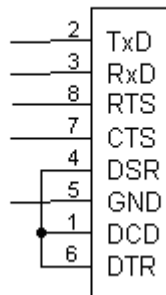

Fig 4-1 RS-232C INTERFACE CONNECTION OF REAR PANEL

4.4 1000A REMOTE CONTROL COMMAND LIST

COMPLEX TYPE FORMAT

State Commands	NOTE	RETURN
[STATe] RANGe{SP}{0.2A 2A 20A 200A 1000A} (; NL)		
[STATe] RANGe{?} (; NL)		0 : 0.2A 1 : 2A 2 : 20A 3 : 200A 4 : 1000A
[STATe :] MODE{SP}{DC AC} (; NL)		
[STATe :] MODE{?} (; NL)		'0' : DC '1' : AC

TABLE 4-1 STAGE COMMAND SUMMARY

System Commands	NOTE	RETURN
[SYStem :] REMOTE(; NL)	Only RS232cmd	
[SYStem :] LOCAL(; NL)	Only RS232cmd	
[SYStem :] NAME {?} (; NL)		"PRODIGIT : 1000A"

TABLE 4-2 SYSTEM COMMAND SUMMARY

Measure Commands	NOTE	RETURN
MEASure : CURRent{?} (; NL)		{#####.#####}[m]{A}

TABLE 4-3 MEASURE COMMAND SUMMARY

4.5 The description of abbreviation

SP : Space, the ASCII code is 20 Hexadecimal.

; : Semicolon, Program line terminator, the ASCII code is 0A Hexadecimal.

NL : New line, Program line terminator, the ASCII code is 0A Hexadecimal.

NR2 : Digits with decimal point. It can be accepted in the range and format of #####.#####.

For Example :

30.12345, 5.0

The description of GPIB programming command syntax.

4.6 Remote Control Command Language description

- { } : The contents of the { } symbol must be used as a part or data of the GPIB command, it can not be omitted.
- [] : The contents of the [] symbol indicates the command can be used or not. It depends on the testing application.
- | : This symbol means option. For example "LOW|HIGH" means it can only use LOW or HIGH as the command, it can choose only one as the setting command.
- Terminator : You have to send the program line terminator character after send the GPIB command, the available command terminator characters which can be accepted in 1000A mainframe is listed in Table 4-4.

LF
LF WITH EOI
CR , LF
CR , LF WITH EOI

TABLE 4-4 GPIB COMMAND TERMINATOR

4.7 Remote control command description

[STATe] RANGe

Syntax : [STATe] RANGe{SP}{0.2A|2A|20A|200A|1000A} (; | NL)

Purpose : Set the 1000A Current shunt range.

Description : This command is set the 1000A Current shunt range.

[STATe] RANGe{?}

Syntax : [STATe] RANGe?

Purpose read the 1000A Current shunt range.

Description : This command is read the 1000A Current shunt range.

0	0.2A
1	2A
2	20A
3	200A
4	1000A

[STATe] MODE

Syntax [STATe :] MODE{SP}{DC|AC} (; | NL)

Purpose : Set the 1000A Current shunt AC or DC mode.

Description : This command is set the 1000A Current shunt AC or DC mode.

[STATe] MODE?

Syntax [STATe :] MODE? (; | NL)

Purpose : Read the 1000A Current shunt AC or DC mode.

Description : This command is read the 1000A Current shunt AC or DC mode.

0	DC
1	AC

[SYStem :] NAME ?

Syntax : [SYStem :] NAME? { ; | NL}

Purpose : Read the model number

Description : This command is for reading the model number. If no module is Operating, the display will be lit "NULL", or it will be lit the model number as table 4-5

MODEL
PRODIGIT : 1000A

TABLE 4-5

[SYStem :] REMOTE

Syntax : [SYStem :] REMOTE { ; | NL}

Purpose : Command to enter the REMOTE status (only for RS232)

Description : This command is for controlling the RS232

[SYStem :] LOCAL

Syntax : [SYStem :] LOCAL { ; | NL}

Purpose : Command to exit the REMOTE status (only for RS232)

Description : This command is for finishing the RS232

MEASure : CURRent ?

Syntax : MEASure : CURRent ? { ; | NL}

Purpose : Read the current

Description : Read the five numbers of current meter, and the unit is Ampere(A)

Appendix A 1000A USB Instruction

1. Install the USB DRIVER, select USB\SETUP\PL-2303 Driver Installer.exe .

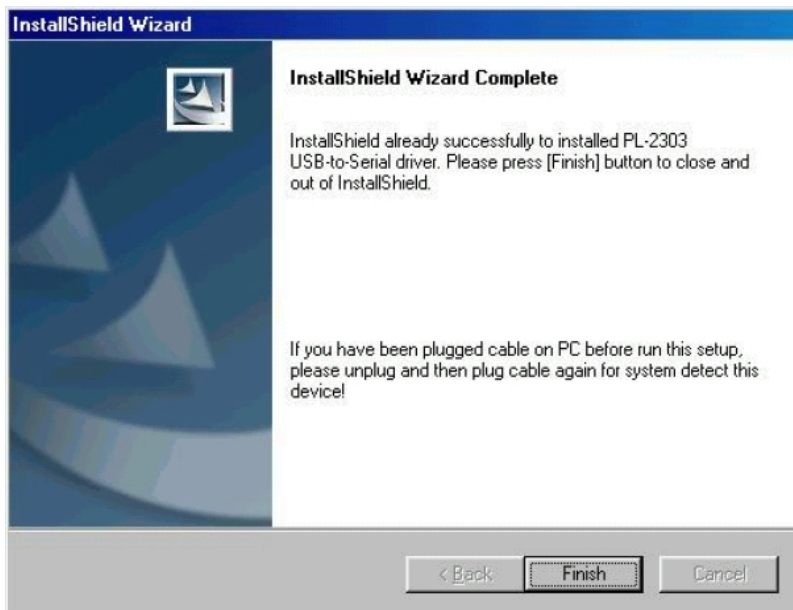
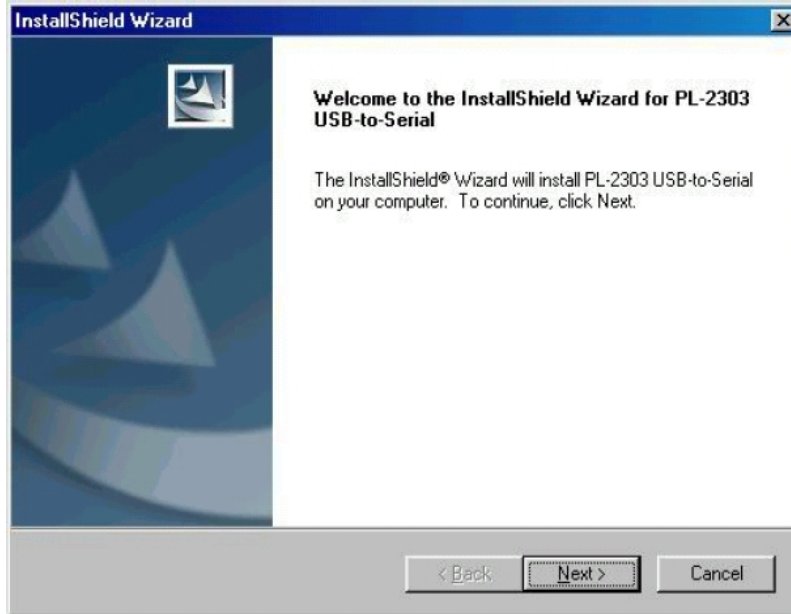

2. After the installation, connect the 1000A and PC with USB. Then select the item USB to Serial Port (COM3), set the BAUD-RATE to 115200bps and the Flow control to Hardware. You should then be able to control the 1000A via USB on COM3.

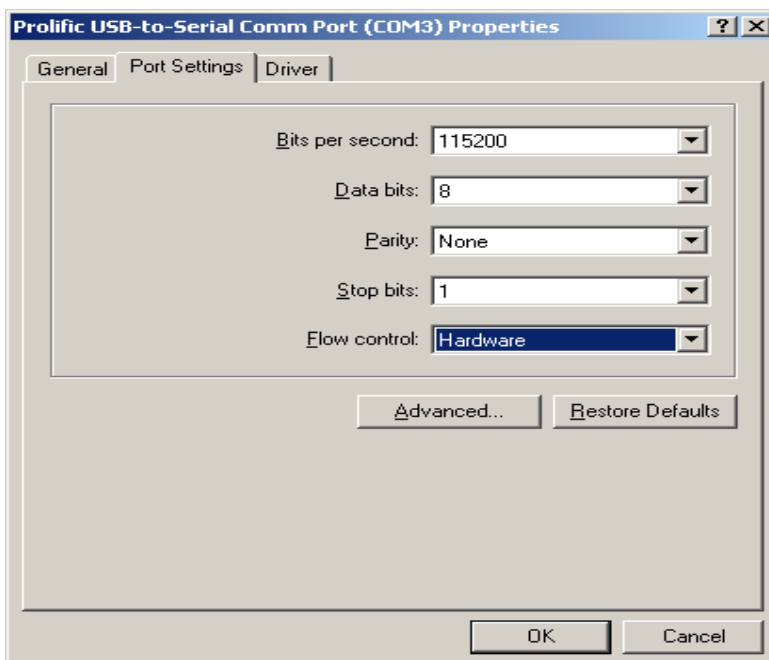
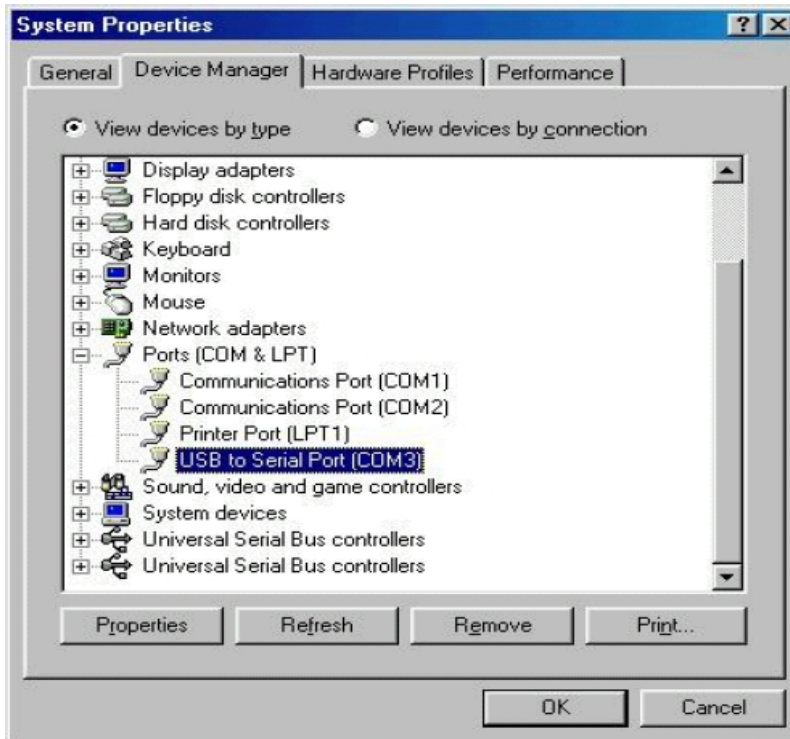

Appendix B: 1000A LAN Installation

1. Connect AC power and the network (LAN) cable to the 1000A mainframe. Connect the other side of the network cable to the existing network.
2. After inserting the driver CD-ROM, run LANETM.EXE from the CD. The Ethernet Manager screen will be displayed as shown in Fig C1-1. If the Ethernet Manager window does not appear then, press F5 to search again (refresh), and check the connections if necessary.

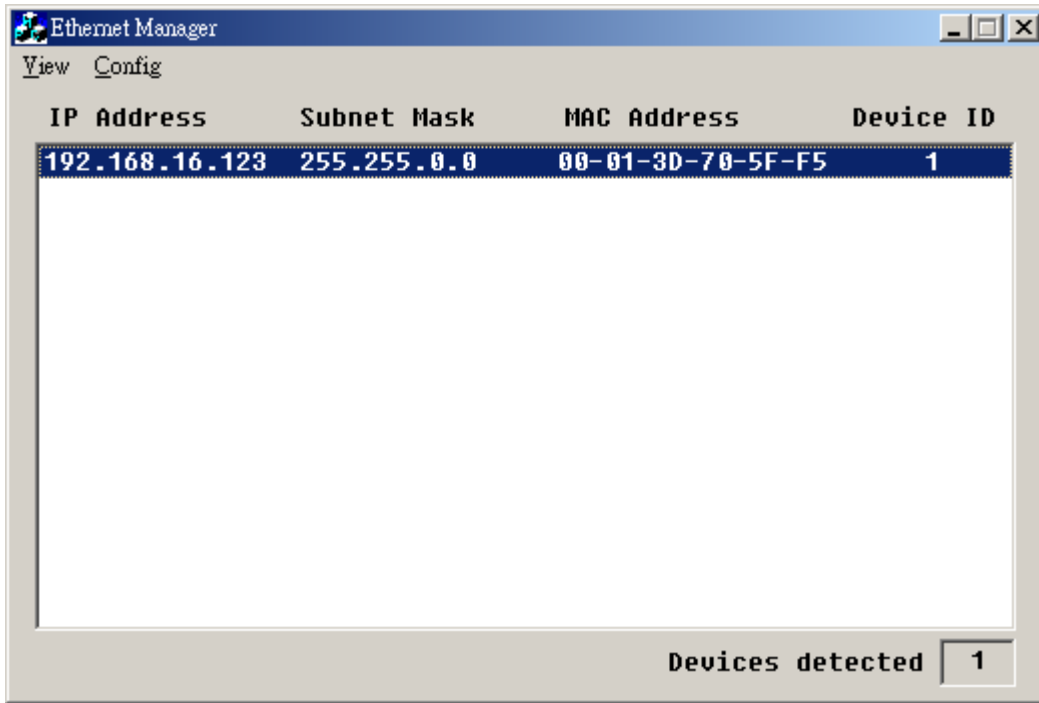
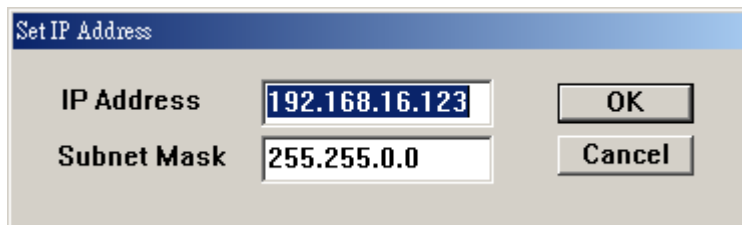

Fig D2-1

3. The connected unit will appear on the list, click it to set the IP Address and Subnet Mask as shown on the following figure.



4. The Controller Setup page should be accessible, once everything is set correctly. This allows greater control over the communications interface.

Controller Setup	
IP address	192.168.16.128
Subnet mask	255.255.255.0
Gateway address	192.168.16.11
Network link speed	Auto
DHCP client	Disable
Socket port of HTTP setup	80
Socket port of serial I/O	4001 TCP Server
Socket port of digital I/O	5001 TCP Server
Destination IP address / socket port (TCP client and UDP)	0.0.0.0 0
Connection	Auto
Serial I/O settings (baud rate, parity, data bits, stop bits)	115200 N 8 1
Interface of serial I/O	RS 232
Packet mode of serial input	Disable
Device ID	5
Report device ID when connected	Disable
Setup password	
Access password	

Update

5. Insert the following into the controller set up screen :

- a) IP Address: **as recommended according to your network**
- b) Subnet Mask: **as recommended according to your network**
- c) Gateway Address: **as recommended according to your network**
- d) Network link speed: **Auto**
- e) DHCP client: **Disable**
- f) Socket port of HTTP setup: **80**
- g) Socket port of serial I/O: **4001**
- h) Socket port of digital I/O: **5001**
- i) Destination IP address / socket port (TCP client and UDP) Connection: **Auto**
- j) Serial I/O settings (baud rate, parity, data, bits, stop bits): **115200, N, 8, 1**
- k) Interface of serial I/O: **RS 232**
- l) Packet mode of serial input: **Disable**
- m) Device ID : **5**
- n) Setup password: **Not required**
- o) Access password : **Not required**